

GRC

Grupo de Redes de Computadores
Computer Networks Group

□ Research Activity Report - June 15, 2011

○ <http://www.grc.upv.es>



- Universidad Politécnica de Valencia, SPAIN
 - Computer Engineering Dept. (DISCA)
 - **GRC**

- ❑ Created in 2000
- ❑ Group structure:

- ❑ 13 Professors:
 - *1 full professor*
 - *10 associate professors*
 - *2 assistant professors*
- ❑ 7 PhD students
 - *3 full-time*
 - *4 part-time*
- ❑ 5 Master students

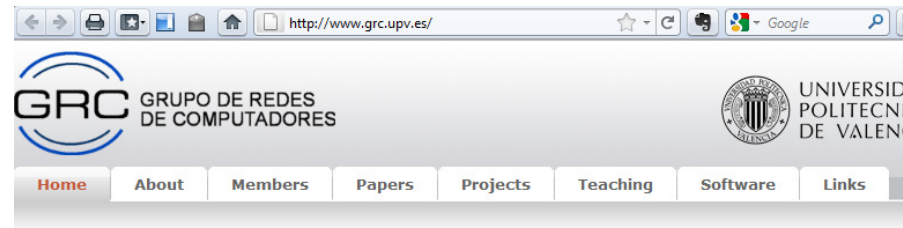

Blogs:

- ▶ [Noticias del GRC](#)
- ▶ [Call for Papers](#)
- ▶ [Photos in Picasa](#)

Conferences:

- ▶ [IEEE IVCS 2010](#)
- ▶ [IEEE IVCS 2011](#)
- ▶ [IEEE Vehi-Mobi 2010](#)
- ▶ [IFIP Networking 2011](#)

- ❑ Autonomous Wireless Networking Systems
 - ❑ based on “mobile ad hoc networks” (MANETs)
- ❑ Areas of application:
 - ❑ Vehicular networks
 - ❑ Sensor networks
 - ❑ Community Networks
 - ❑ Ubiquitous Computing

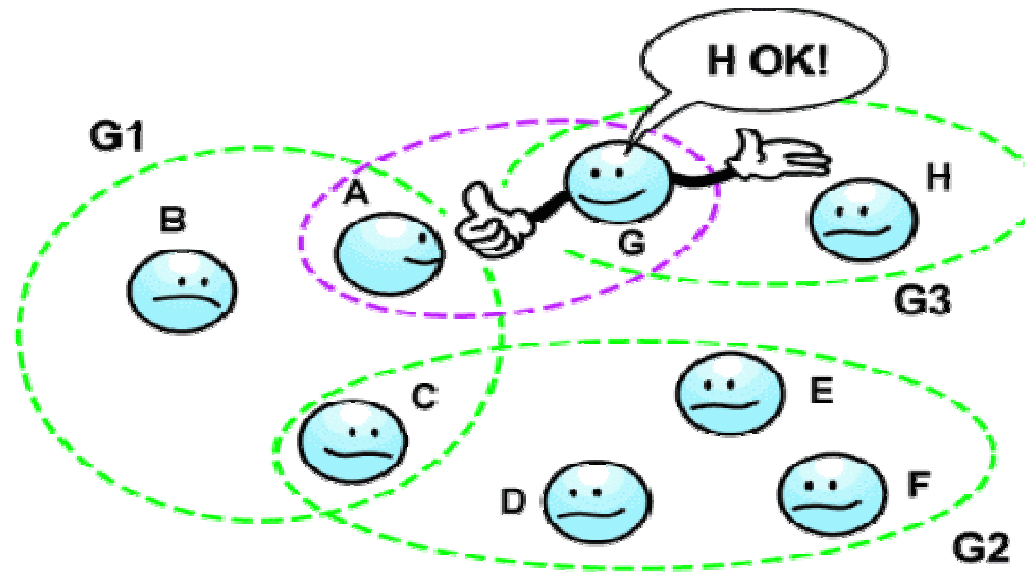

GRC work methodology

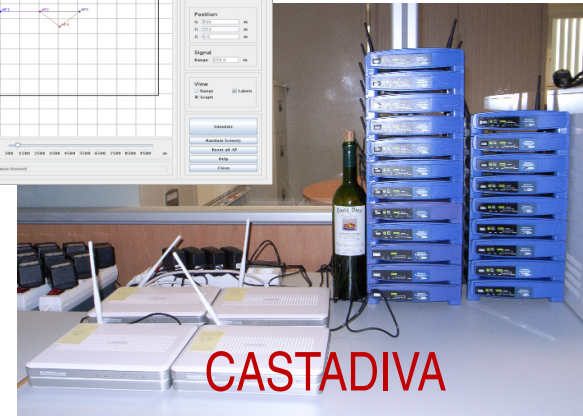
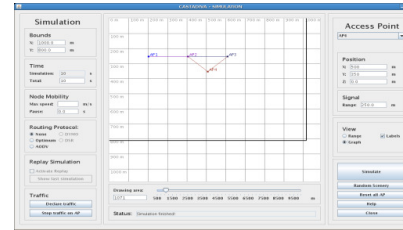
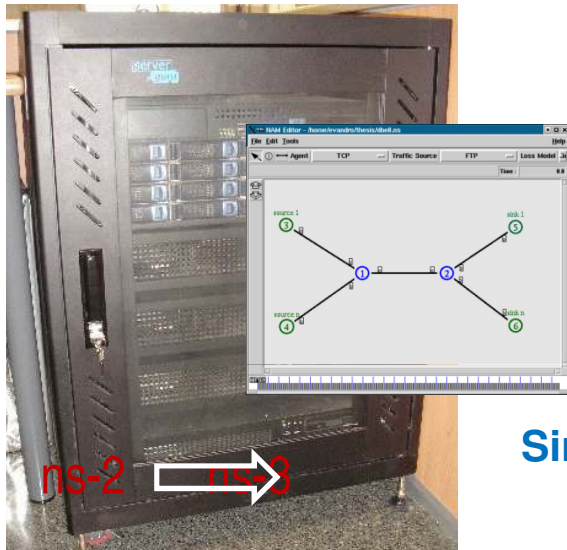

Simulation

Emulation



Prototyping

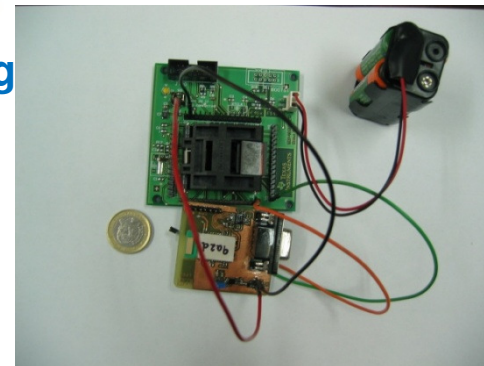

- A MANETs emulator

<http://castadiva.sourceforge.net/>



CASTADIVA: Interface

The screenshot displays the CASTADIVA - SIMULATION interface, which is divided into several functional areas:

- Simulation Panel (Left):**
 - Bounds:** X: 1000.0 m, Y: 800.0 m
 - Time:** Simulation: 10 s, Total: 10 s
 - Node Mobility:** Max speed: [] m/s, Pause: 0.0 s
 - Routing Protocol:** Radio buttons for None (selected), DYMO, Optimum, DSR, and AODV.
 - Replay Simulation:** Activate Replay, Show last simulation button.
 - Traffic:** Declare traffic button, Stop traffic on AP button.
- Central Grid:** A 1000m x 1000m grid with four Access Points (AP1, AP2, AP3, AP4) and their connections. AP1, AP2, and AP3 are connected in a line, while AP4 is connected to AP2.
- Access Point Panel (Right):**
 - Access Point:** AP4 (selected from dropdown)
 - Position:** X: 500 m, Y: 350 m, Z: 0.0 m
 - Signal:** Range: 250.0 m
 - View:** Radio buttons for Range and Graph (selected), with a checked Labels checkbox.
 - Buttons:** Simulate, Random Scenery, Reset all AP, Help, Close.
- Bottom Panel:**
 - Drawing area:** A slider ranging from 500 to 9500 m, currently set at 1071.
 - Status:** Simulation finished!

Research activities on ITS of the UPV Networking Group (GRC)



- VANETS Simulation and Modelling
- eNOTIFY project
- eSBR: a warning advertisement systems
- Content Broadcasting
- ... future plans ...

Realistic attenuation and visibility models (RAV)

□ Problem statement:

- The radio propagation models are typically unrealistic.
- The physical obstacles present in urban environments (mostly buildings) are not taken into account.

□ Therefore:

- The results obtained are too optimistic.
- Uncertainty about the validity of proposed solutions.

□ Our goals:

- Simulate real roadmap scenarios
- Take into account the impact of the buildings in signal propagation
- Introduce new radio propagation models (RPMs) that increase the level of realism of the experiments:
- Reduce to a minimum the computational overhead:
 - *Simulators (ns-2) are already too slow*
 - *Changes in the channel model are critical: $O(n)$ time increase*

RAV: Simulating real roadmap scenarios

- Step 1: www.openstreetmap.org



RAV: Simulating real roadmap scenarios

□ Step 2: SUMO

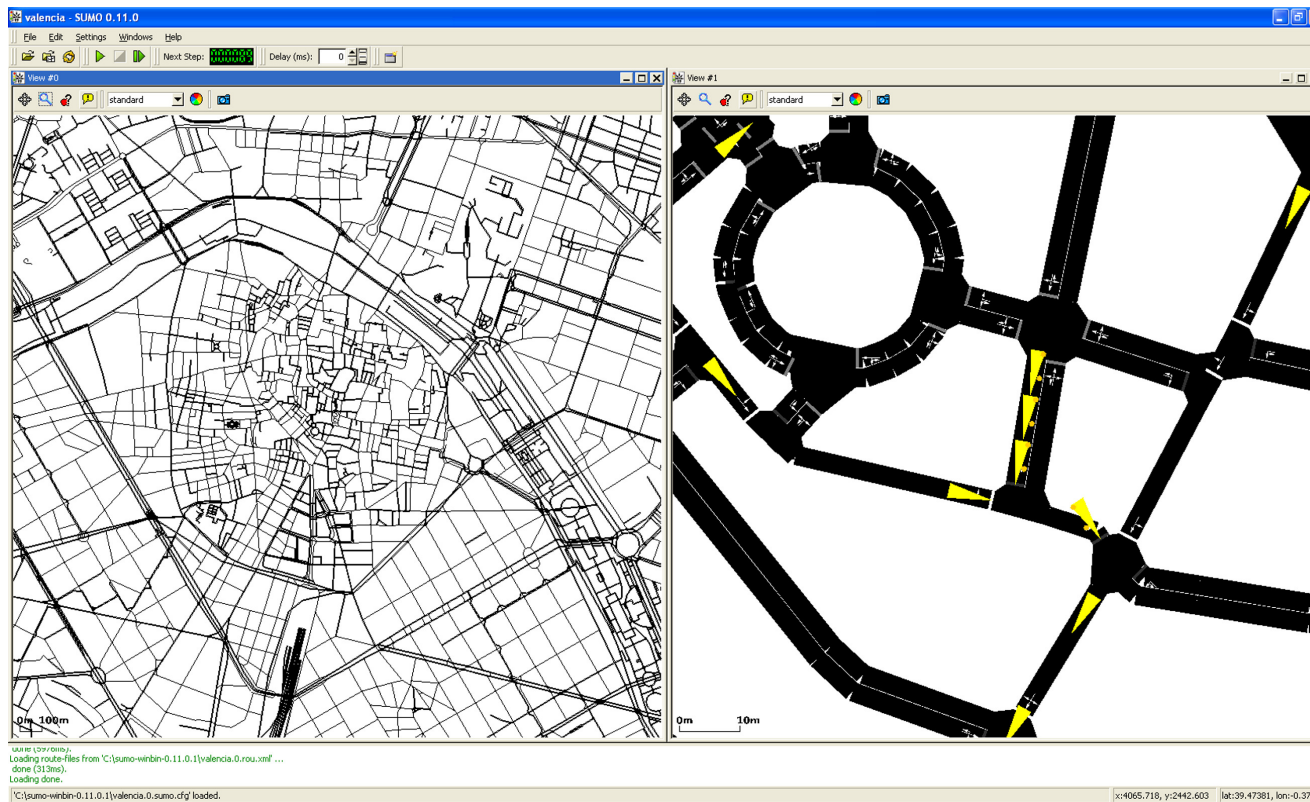

RAV: Simulating real roadmap scenarios

- ❑ Step 3: ns-2 and CityMob
 - ❑ Models random direction changes
 - ❑ Simulates semaphores at random positions (not only in crossing), and with different delays
 - ❑ Adds traffic density. Vehicles must move slower than in the outskirts
 - ❑ User can change the probability of a node being located inside the downtown area

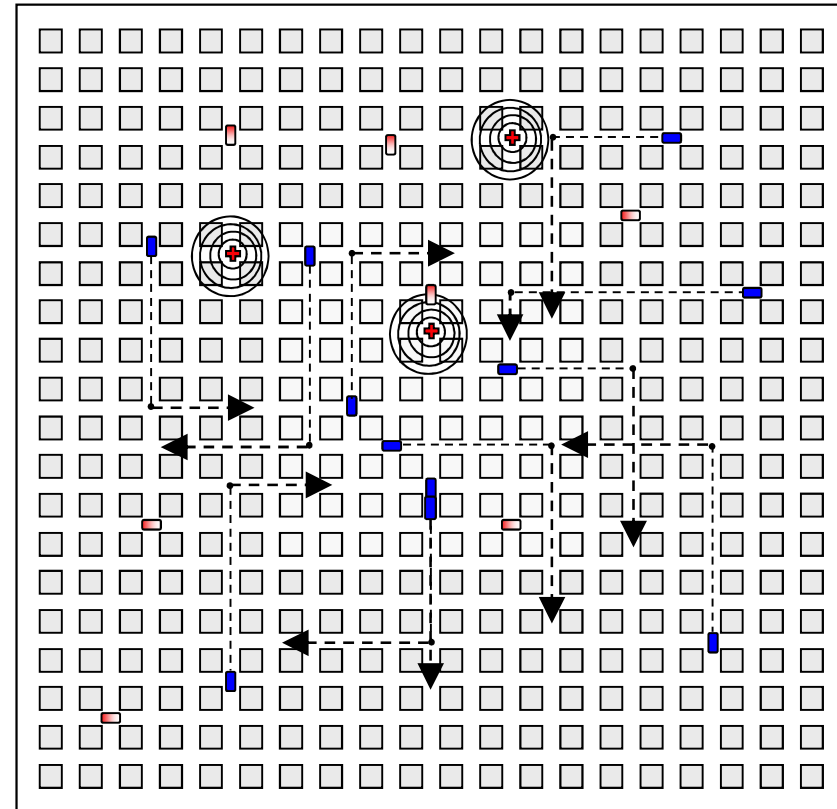

RAV: CityMob for Roadmaps (C4R)

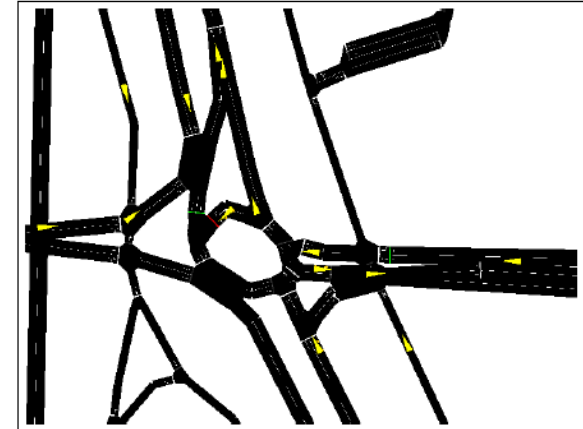
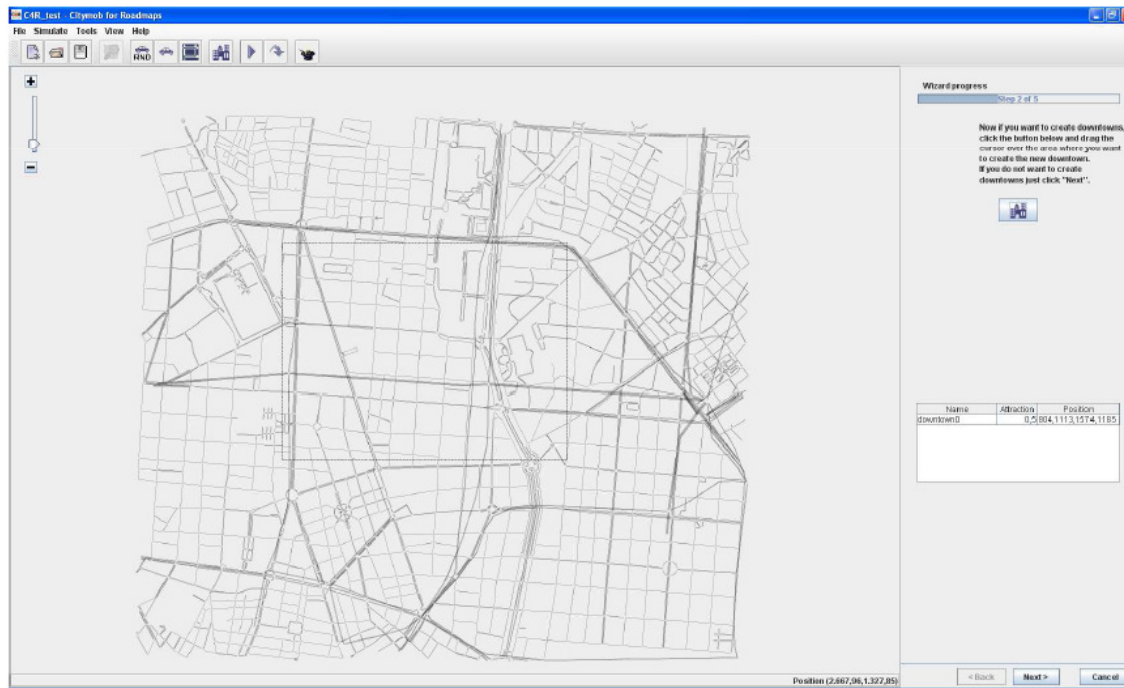

| Component | Minimum requirements |
|----------------------|----------------------|
| Processor | Pentium IV |
| Hard disk | 10 GB |
| RAM | 1.5 GB |
| Screen resolution | 1024x768 |
| Platform | MAC/Linux/Windows |
| Java runtime version | Java 6 SE |
| SUMO version | 0.11.1 |
| Internet connection | 56K connection |

RAV: Radio Propagations Models

- ❑ Realistic Radio Propagation Models (RPMs)
 - ❑ Distance Attenuation Model (DAM)
 - ❑ Building Model (BM)
 - ❑ Building and Distance Attenuation Model (BDAM)

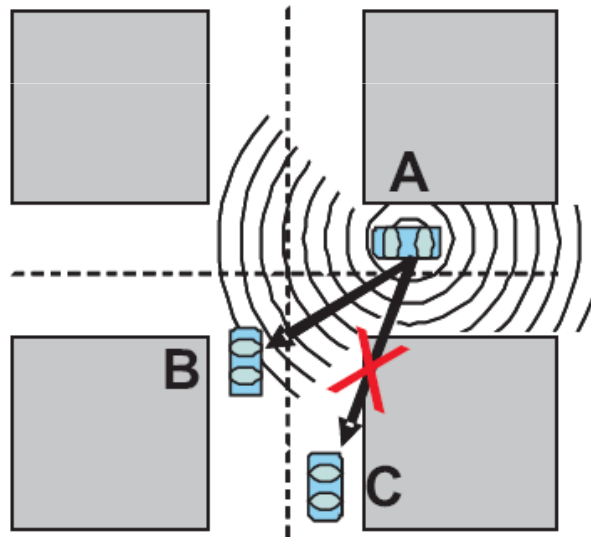

Research activities on ITS of the UPV Networking Group (GRC)



- ❑ VANETS Simulation and Modelling
- ❑ eNOTIFY project
- ❑ eSBR: a warning advertisement systems
- ❑ Content Broadcasting
- ❑ ... future plans ...

eNotify: the pan-European eCall concept

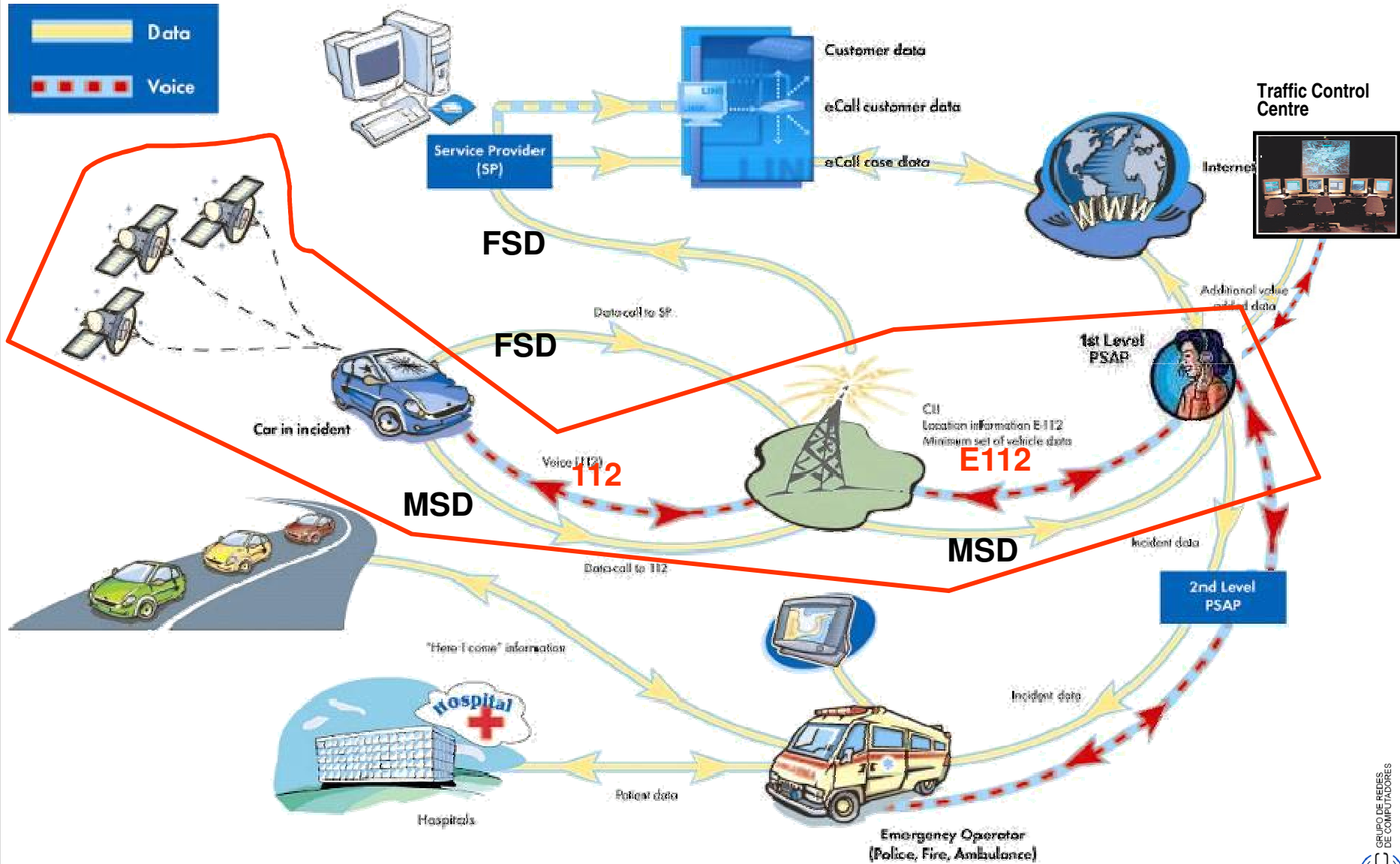

eNotify: Industrial partner

- **Applus+ IDIADA** is dedicated to product development in the automotive sector, offering engineering, testing and homologation services to the industry world-wide. Applus+ IDIADA undertakes global vehicle development projects for the principal manufacturers and has consolidated its position as a reference in the sector.
- Applus+ was created in 1996 to enter the U.S. marketplace into the vehicle emissions sector. Today, Applus+ employs over 8,200 employees in 29 countries with businesses ranging from automotive inspection and maintenance, to certifications, technological services and damage and survey claims.

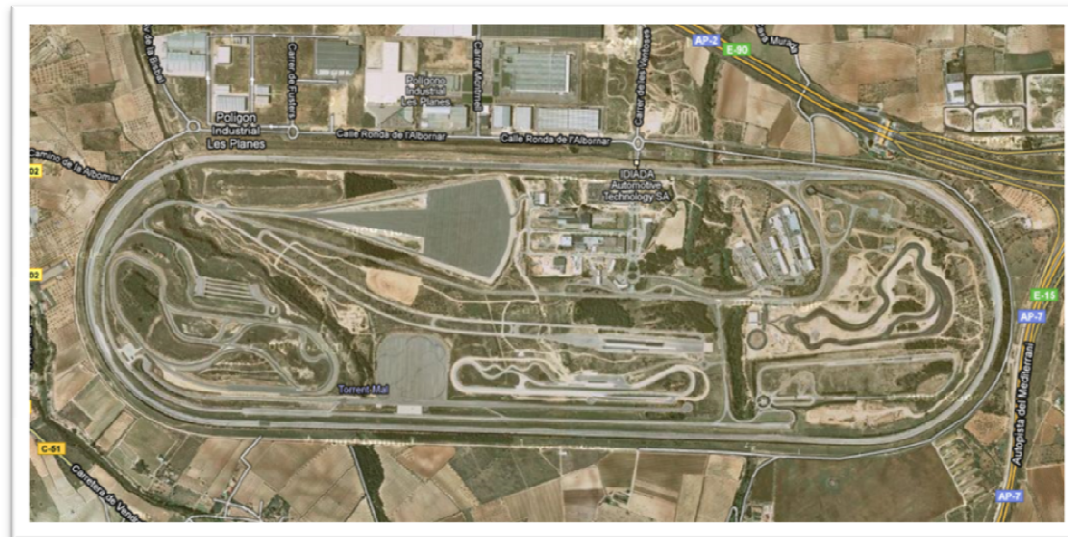

eNotify: basic architecture

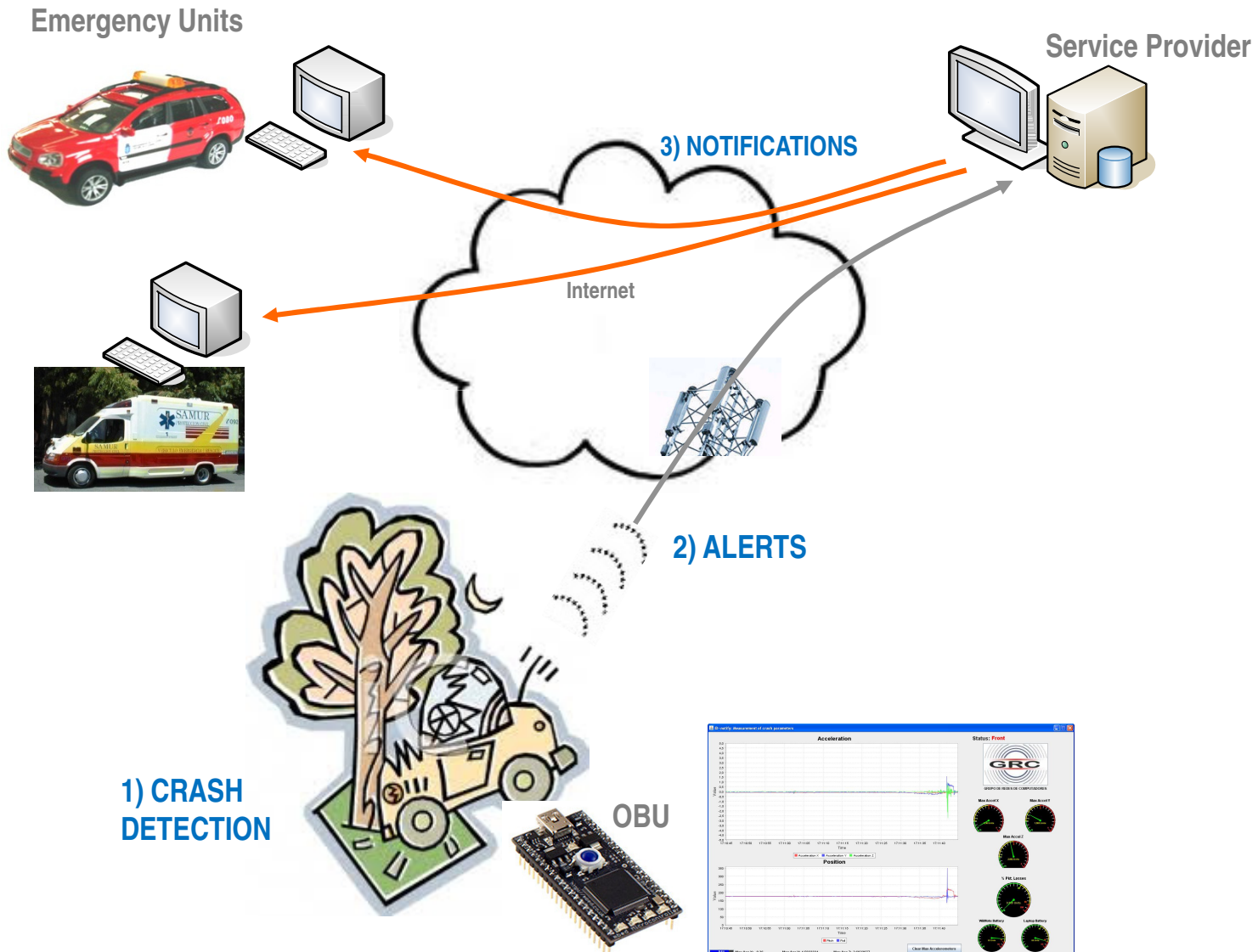

eNotify: first crash tests



Barcelona International Motor Show 2009.
May 9th, 2009

More picture and a video, here:
<http://www.grc.upv.es/600/activities.html>

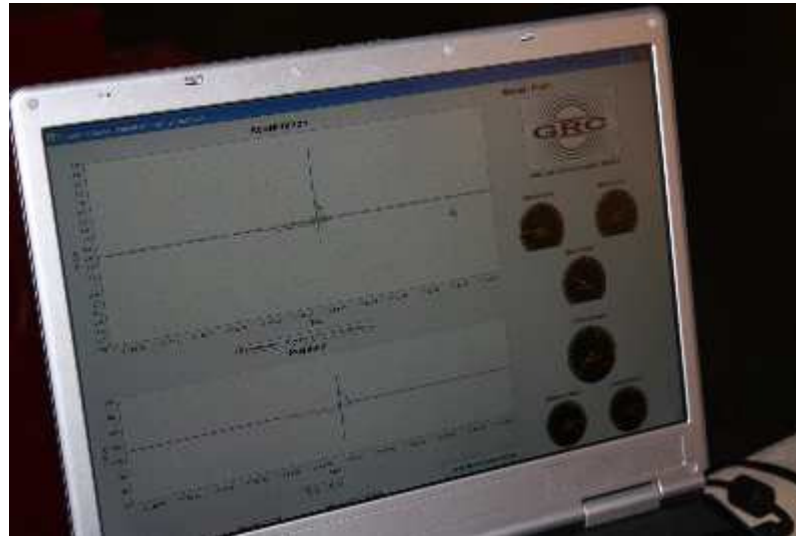

eNotify: in-vehicle system (IVS) evolution

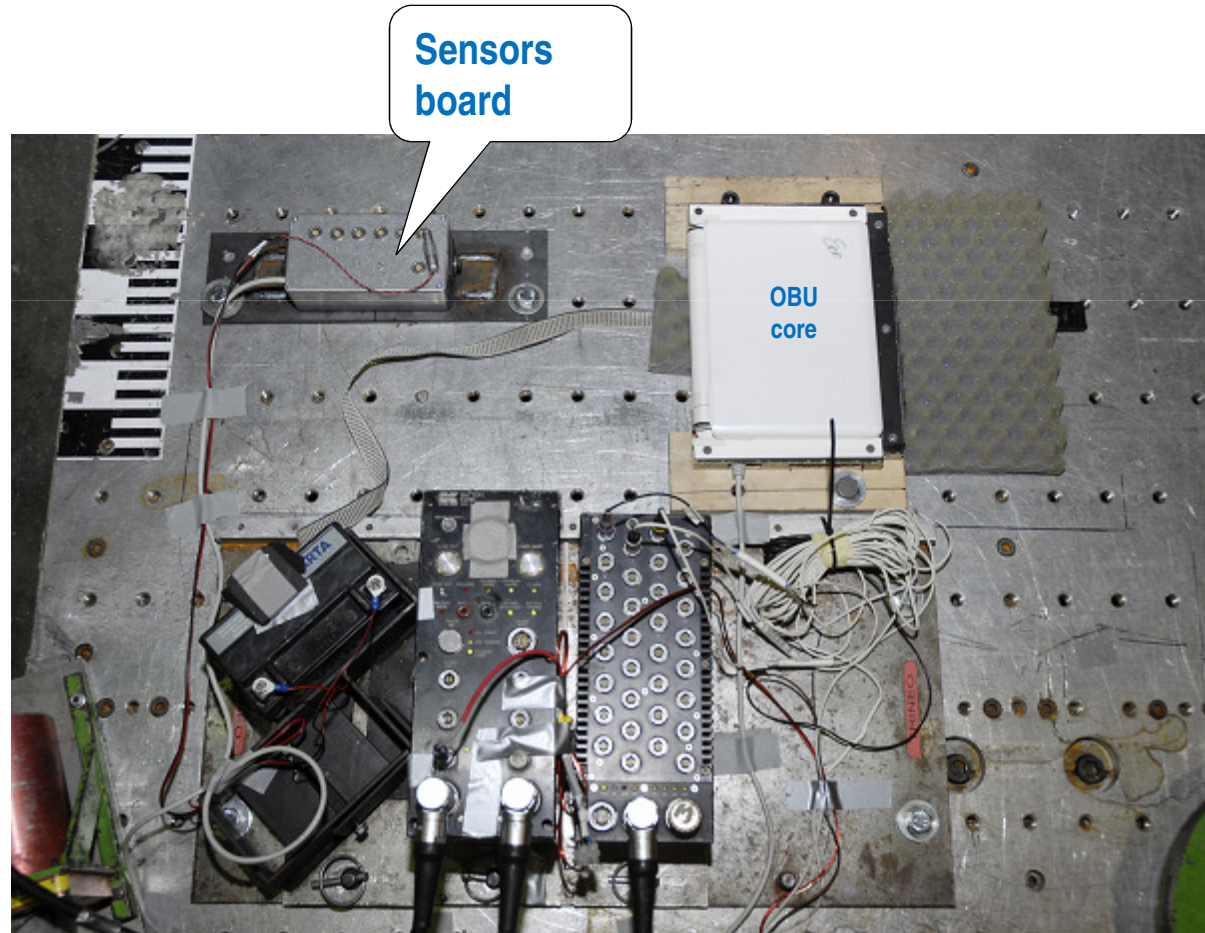
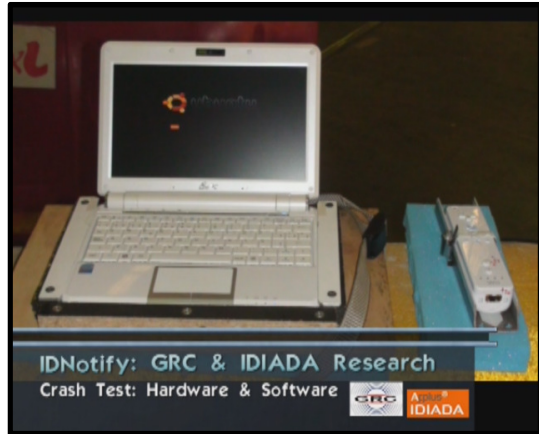

eNotify: in-vehicle system (IVS) details

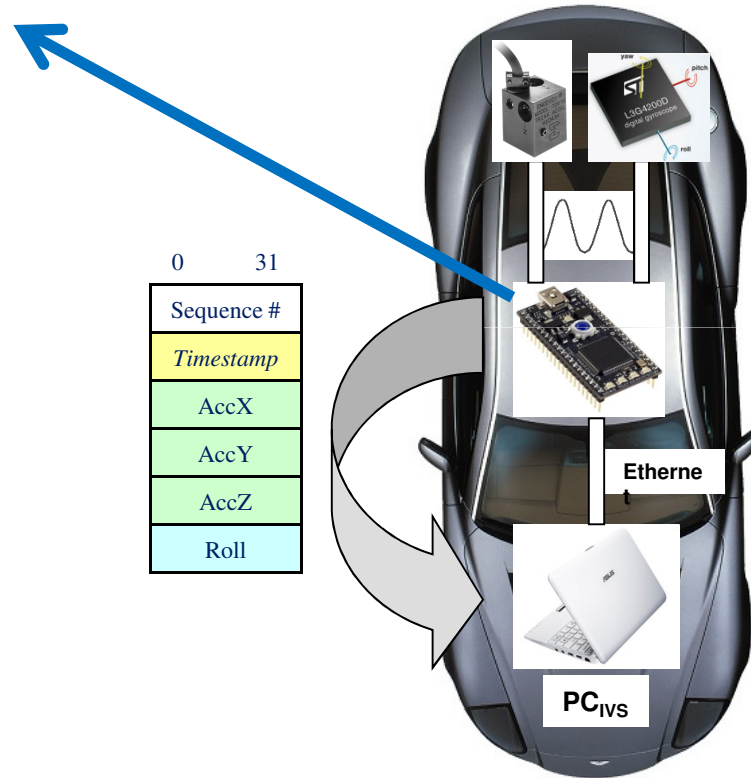
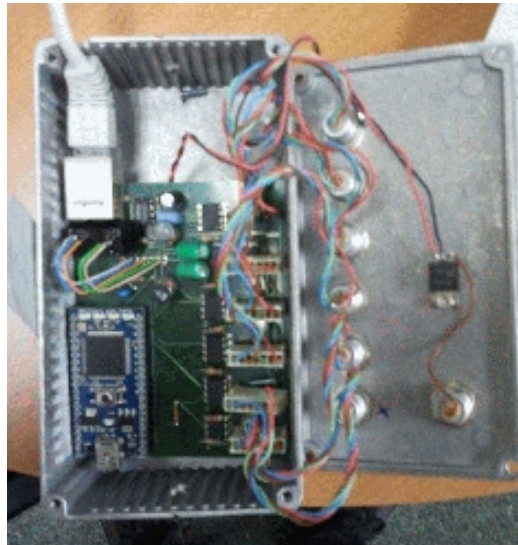

| 0 | 31 |
|------------|----|
| Sequence # | |
| Timestamp | |
| AccX | |
| AccY | |
| AccZ | |
| Roll | |

| 0 | 31 |
|------------|----|
| Sequence # | |
| Timestamp | |
| AccX | |
| AccY | |
| AccZ | |
| Roll | |
| StateFront | |
| StateSide | |
| StateBack | |
| StateRoll | |

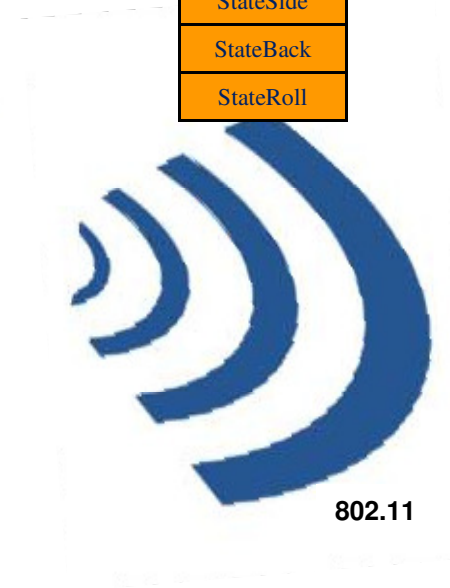

802.11

Frontal impact: acceleration graphs

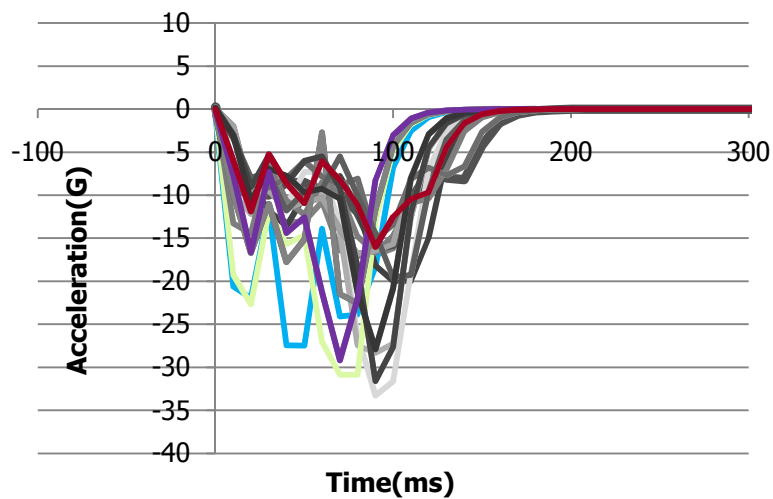

- Approximated by trapezoids with consecutive measurements
- Necessary to determine the initial time, duration and threshold

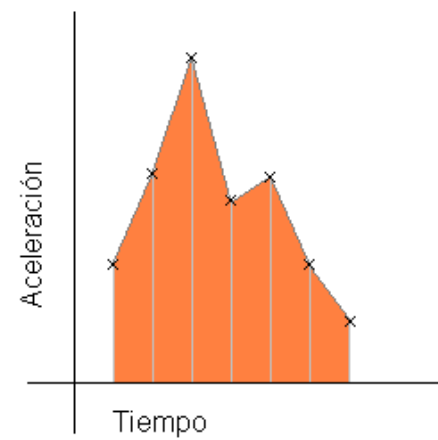
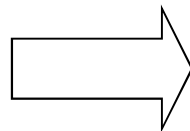
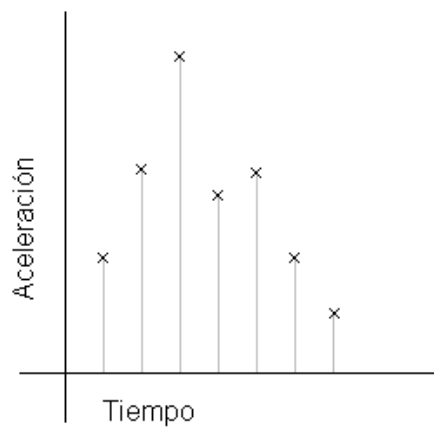

eNotify: next steps

- ❑ Alerts propagation
 - ❑ eSBR
 - ❑ Alerts fusion
- ❑ Integration with more sensors
 - ❑ Improve car crash detection
- ❑ Also:
 - ❑ Video-communication between car and CU
 - ❑ Increase fault-tolerance
- ❑ ...

Research activities on ITS of the UPV Networking Group (GRC)



- ❑ VANETS Simulation and Modelling
- ❑ eNOTIFY project
- ❑ eSBR: a warning advertisement systems
- ❑ Content Broadcasting
- ❑ ... future plans ...

eSBR: a warning advertisement systems



- ❑ In a warning advertisement system:
 - ❑ Collided vehicles periodically broadcast their conditions
 - ❑ When other vehicles receive these warning messages, they store and immediately forward them by re-broadcasting the message
 - ❑ Warning messages should be propagated to all vehicles in the target area
- ❑ In urban environments an accident can cause many vehicles to send warning messages.
- ❑ **The broadcast storm problem.**

eSBR: an example



eSBR: core algorithms

Algorithm 1: eSBR_Send()

```

Pw = AC3; // set the highest priority
Pb = AC1; // set default priority
ID = 0; // initialize sequence number of messages
while (1) do
  if (vehiclei is in warning mode) then
    create message m;
    set m.priority = Pw;
    set m.seq_num = ID++;
    broadcast warning message (m);
    sleep (Tw);
  else
    create message m;
    set m.priority = Pb;
    broadcast beacon (m);
    sleep (Tb);

```

Algorithm 2: eSBR_OnRecv()

```

for (every received message) do
  if (m is a warning and m.seq_num received for the first time)
  then
    if (distance between sender and receiver > D or both vehicles
    are in different streets) then
      rebroadcast(m);
    else
      discard(m);
      /* warnings are only rebroadcasted when additional coverage
      area is high or they can be propagated to different streets */
  else
    discard(m);
    // duplicated warnings and beacons are not rebroadcasted

```

Research activities on ITS of the UPV Networking Group (GRC)



- ❑ VANETS Simulation and Modelling
- ❑ eNOTIFY project
- ❑ eSBR: a warning advertisement systems
- ❑ Content Broadcasting
- ❑ ... future plans ...

Content broadcasting in vehicular networks

- ❑ Challenge: deliver contents to highly mobile receivers (vehicles)
- ❑ E.g., a possible scenario:
 - ❑ A private corporate server broadcasts announcements to passing vehicles offering information of local interest
 - *e.g. news, special offers, prices, etc.*
 - *interested vehicles capture broadcasted information while moving*

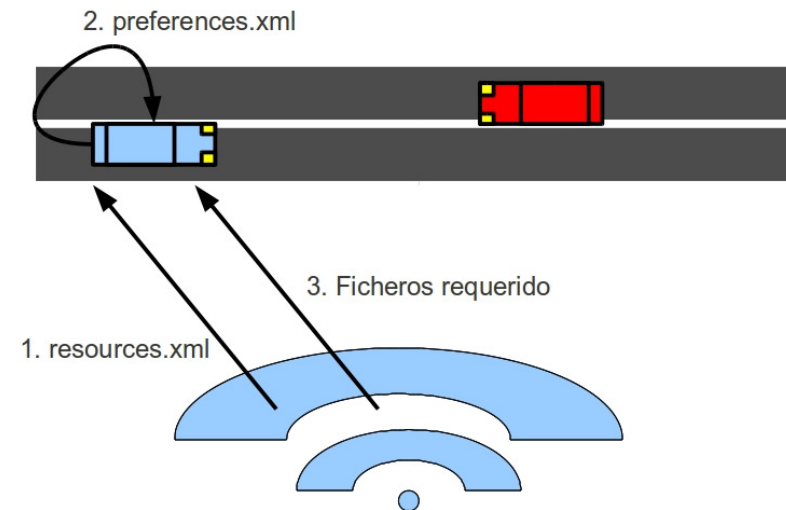
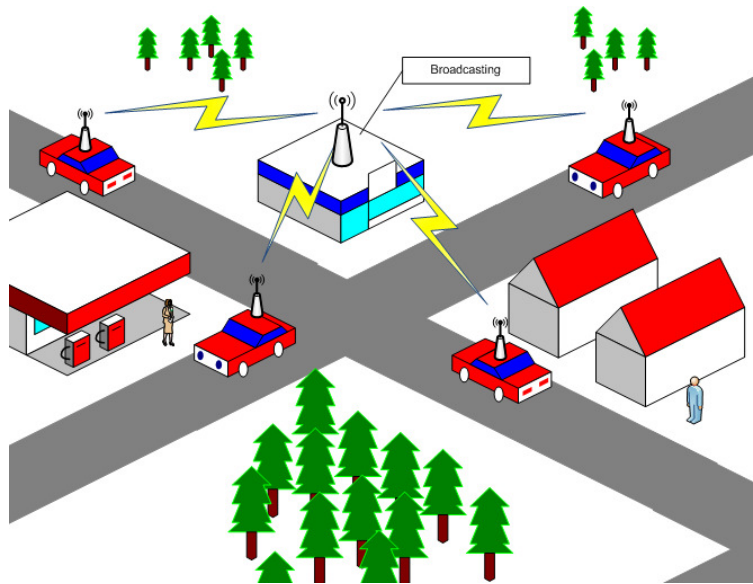

- Application Layer FEC (AL-FEC) coding has recently emerged as an important solution to compensate for packet losses in Binary Erasure Channels (BEC) like the Internet or wireless networks.
- In this field, Raptor codes are increasingly becoming one of the main rateless coding solutions, **mainly due to their computational efficiency.**

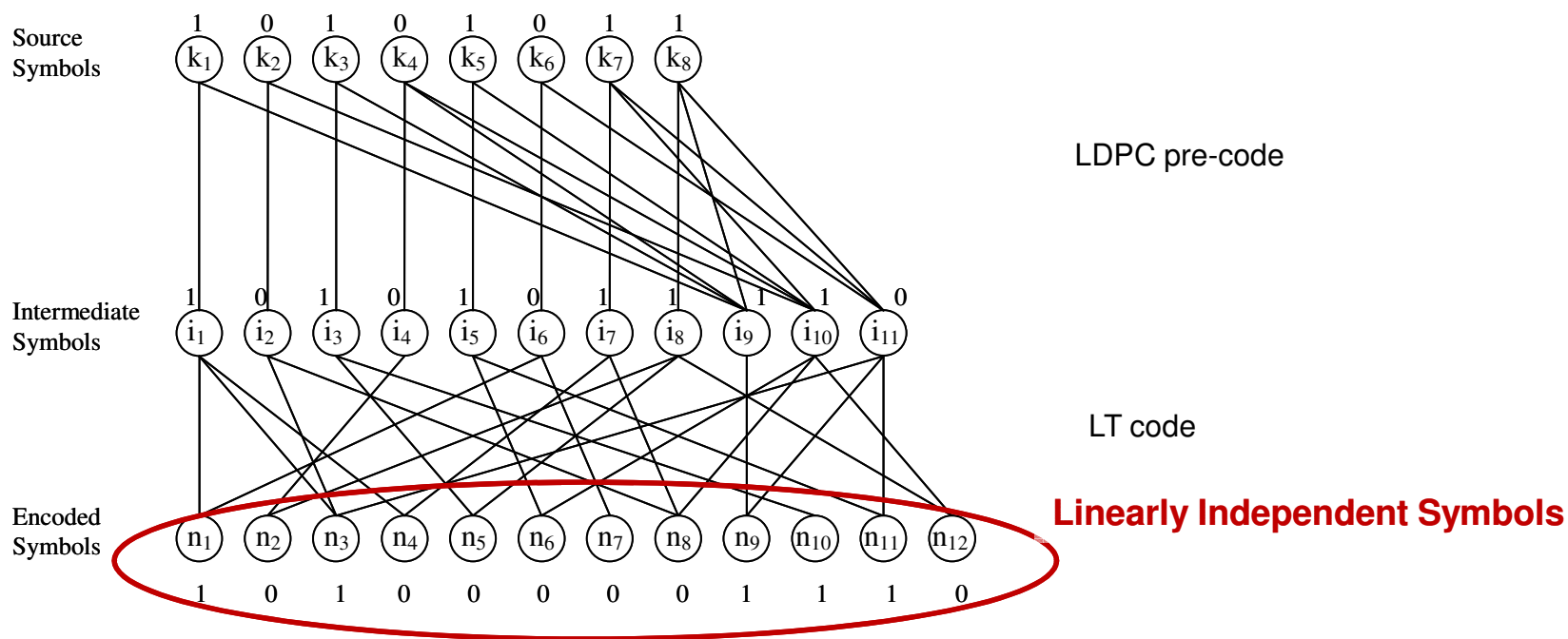

RCDP: Raptor-based Content Delivery Protocol

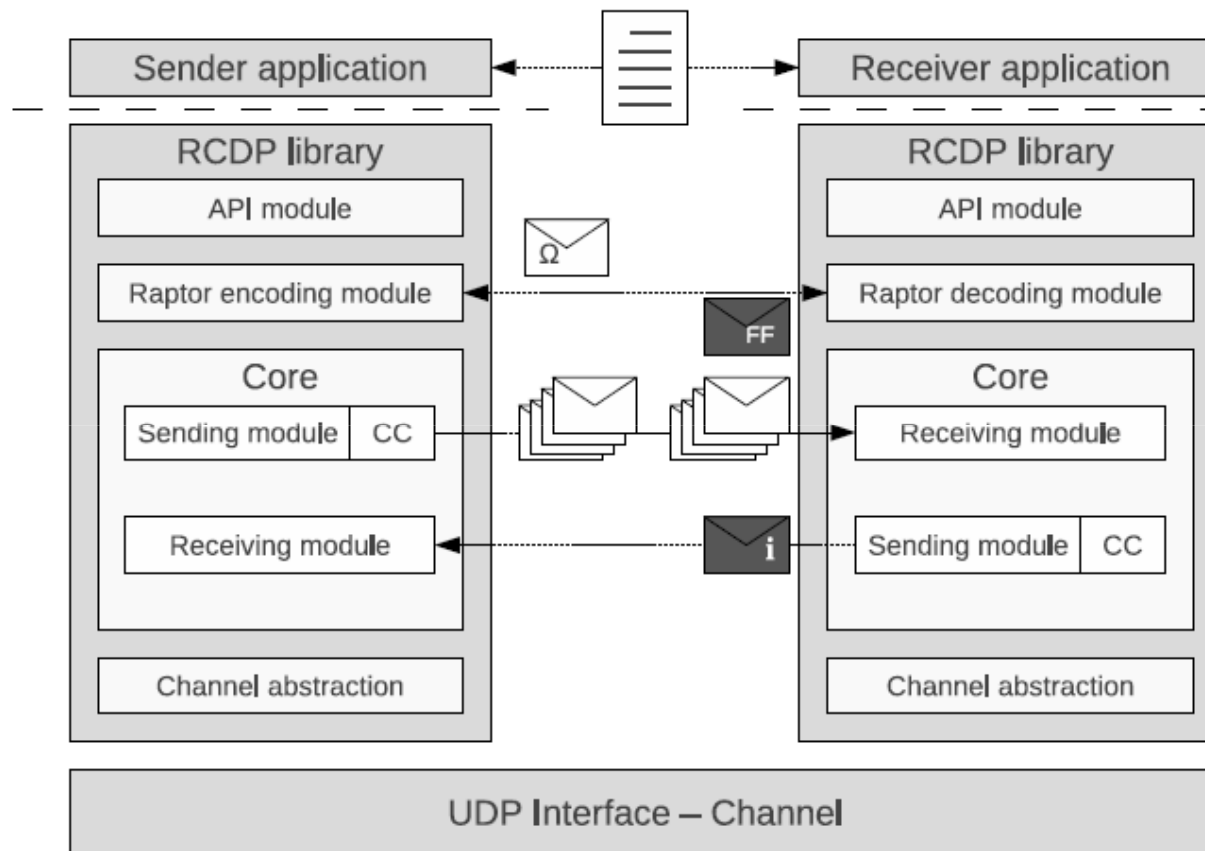

- ✓ **burst rate transmission** is continuously adjusted according to the available channel bandwidth
- ✓ **UDT library** used as transport layer framework
 - ✓ Y. Gu and R. Grossman, "UDT: UDP-based data transfer for high-speed wide area networks," *Computer Networks*, vol. 51, no. 7, 2007.

Research activities on ITS of the UPV Networking Group (GRC)



- ❑ VANETS Simulation and Modelling
- ❑ eNOTIFY project
- ❑ eSBR: a warning advertisement systems
- ❑ Content Broadcasting
- ❑ ... future plans ...

Toward a Smart Architecture To Collect Vehicles and Environment Data

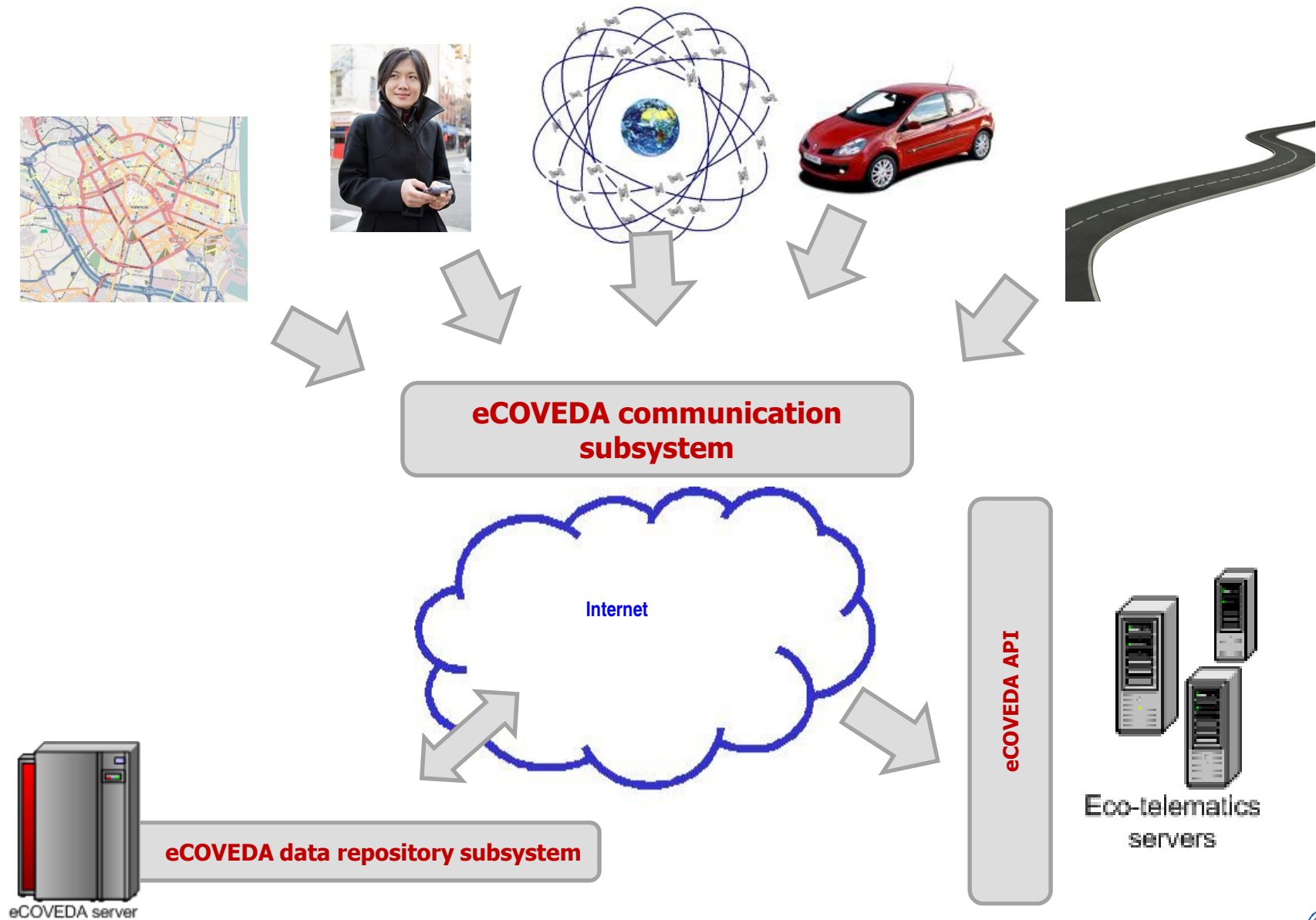

Smartphones as sensors: "BlackBox OBD DROID"



Sensors
G-Sensor
Digital compass
Proximity sensor
Ambient light sensor

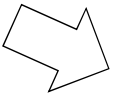

GPS

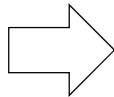
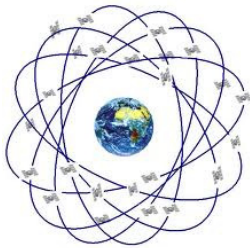

OBD-II
Wireless
Transceiver

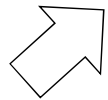

Android based smartphone

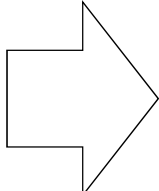

Emergency Units

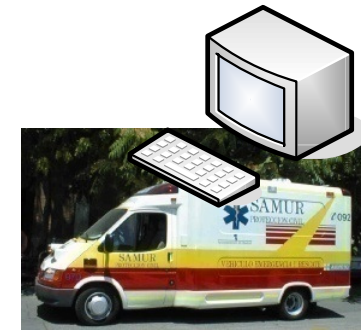

SMS/email
&
Phone call

Smartphones as sensors: "BlackBox OBD DROID"

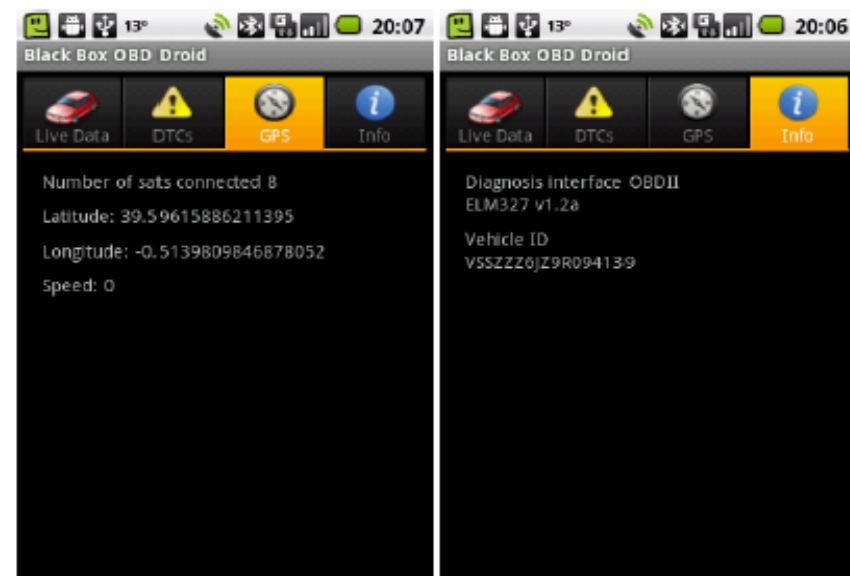
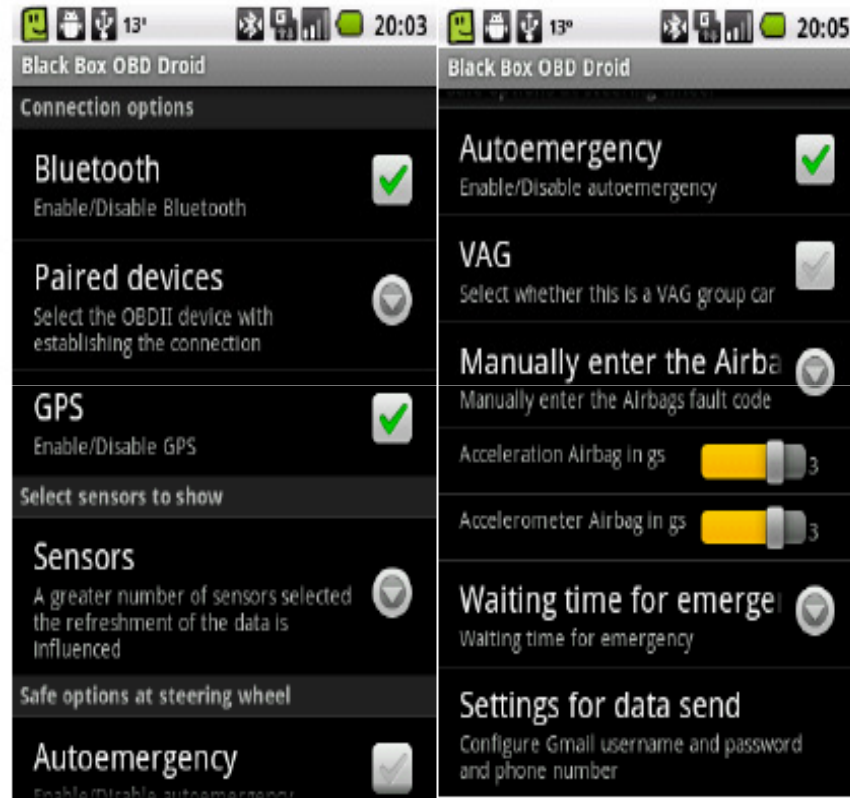

Vertical Handover

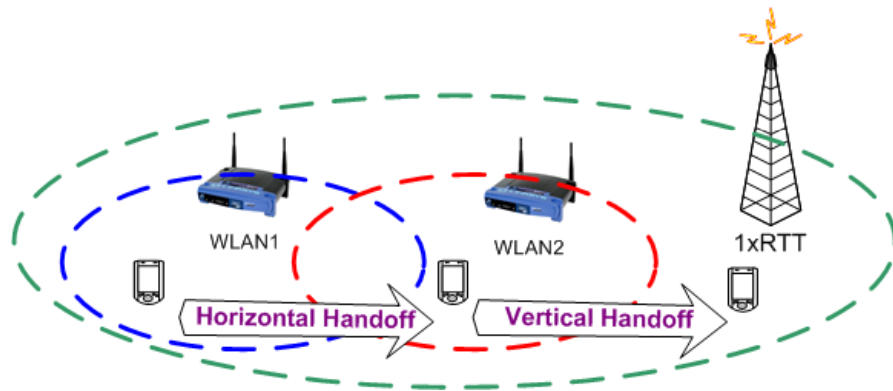

- ❑ A seamless handoff is defined as a handoff scheme that maintains the connectivity of all applications on the mobile device when the handoff occurs.
- ❑ Two goals: low latencies and few packet losses
- ❑ Standard: IEEE 802.21
- ❑ Context aware based approach

Sensor Networks

□ MRLG

Wireless sensor networks for critical tasks

- we developed an event generation framework compatible with the ns-2 simulator that includes tools to model intruder detection events, as well as fire/gas propagation scenarios.

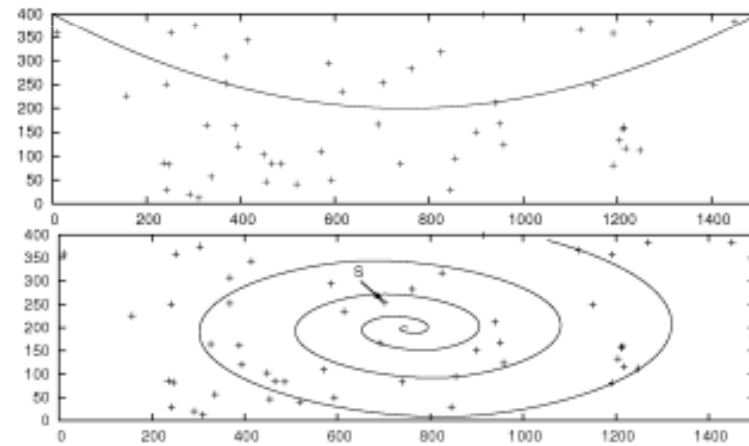
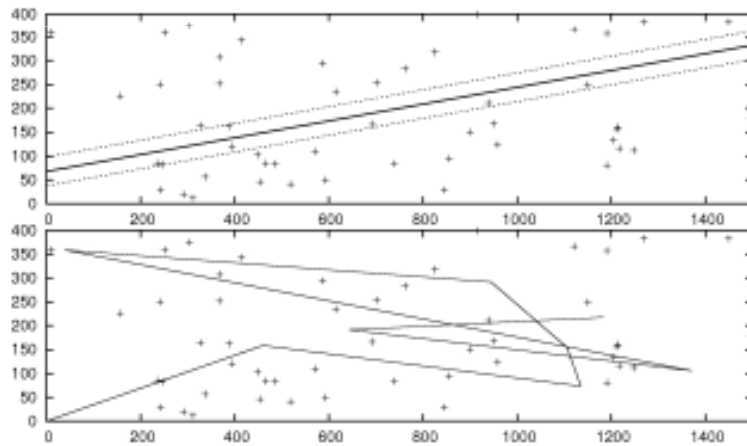

Community Networks

- Ruralnet
- Ruralnet 2.0 & Guifinet
- Security
 - Active attacks
 - Passive attacks

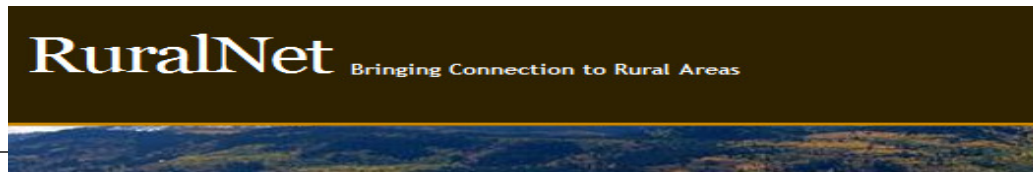

<http://ruralnet.sourceforge.net/>

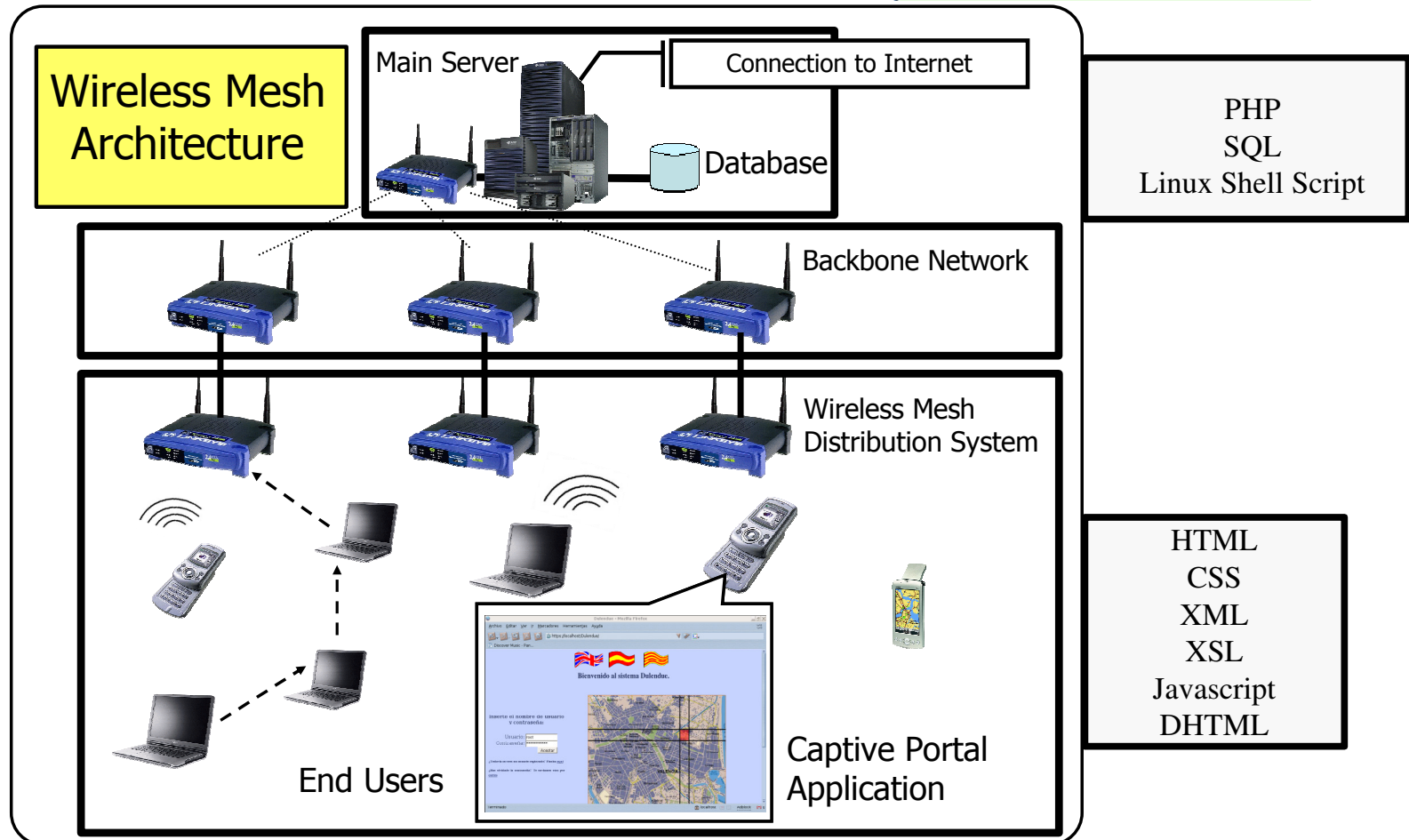

GRC and TeSo deployed RuralNet in Mozambique

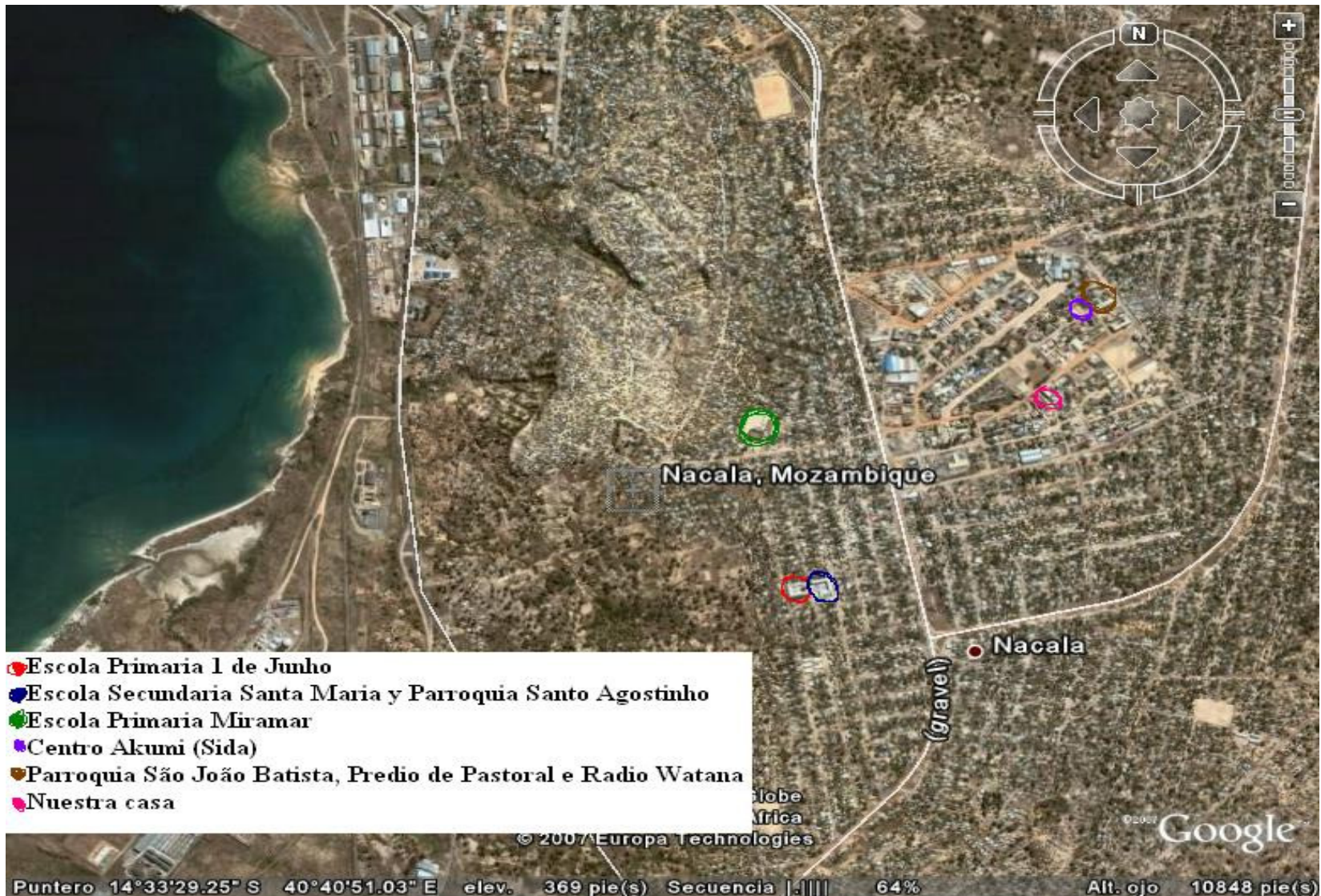



- ❑ Load balancing
- ❑ Routing optimization
- ❑ Hot-Spots management

OpenWrt Admin Console

Maya Project v0.1

Acercar de -Información del router-

Información del router

WHITE RUSSIAN (RCS)

WHITE RUSSIAN (RCS) -----
 * 2 oz Vodka. Mix the Vodka and Kahlua together
 * 1 oz Kahlua over ice, then float the cream or
 * 1/2oz cream milk on the top.

Versión del firmware: WHITE RUSSIAN (RCS)

Versión del Kernel: Linux version 2.4.30 (nbd@ux-2y02) (gcc version 3.4.4 (OpenWrt-1.0)) #1 Sun Mar 26

Nombre: 19:02:04 CEST 2006

Fecha/Hora: Fri Jan 21 21:39:02 UTC 2000

Dirección MAC: 00:13:10:3F:94:50

Terminado

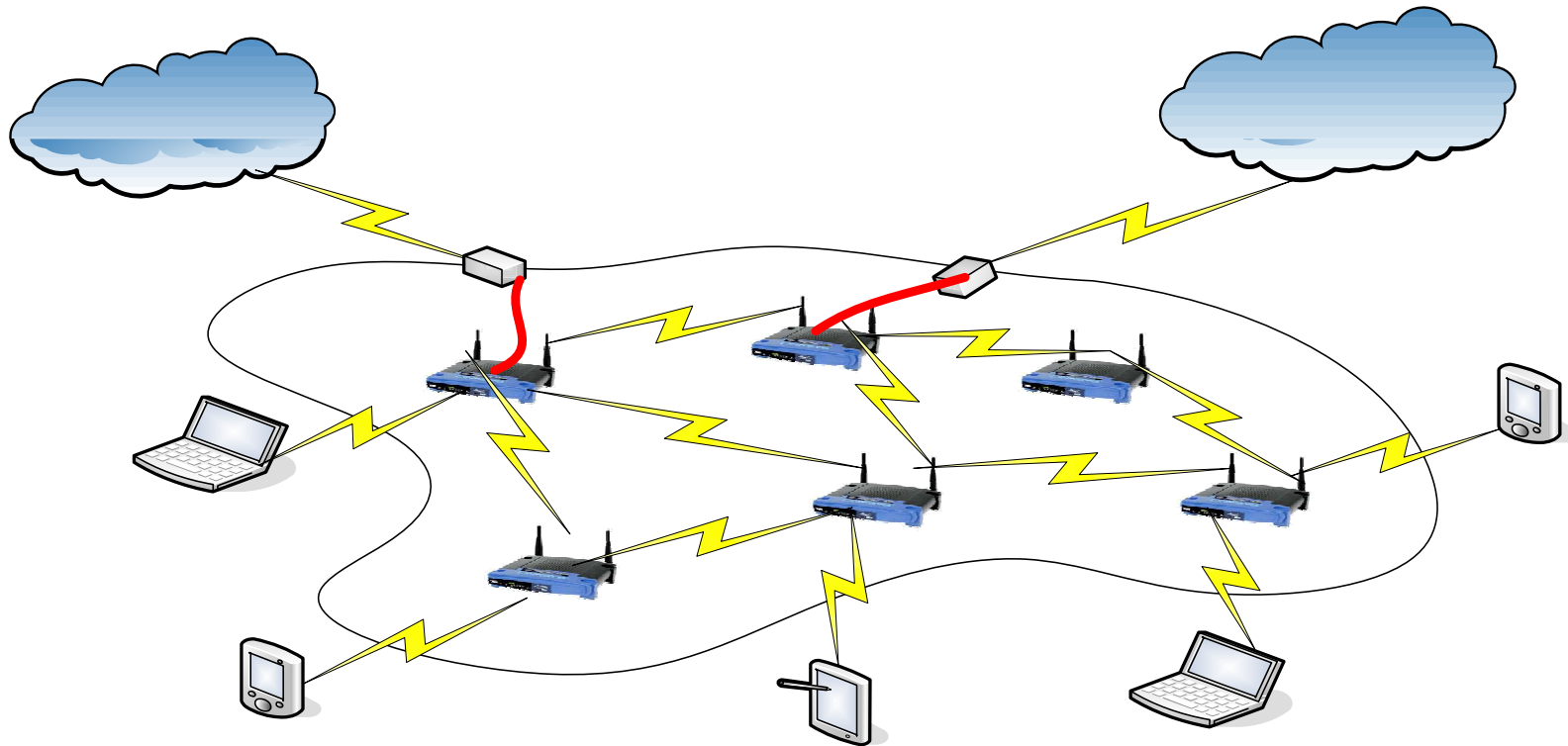

Security attacks classification

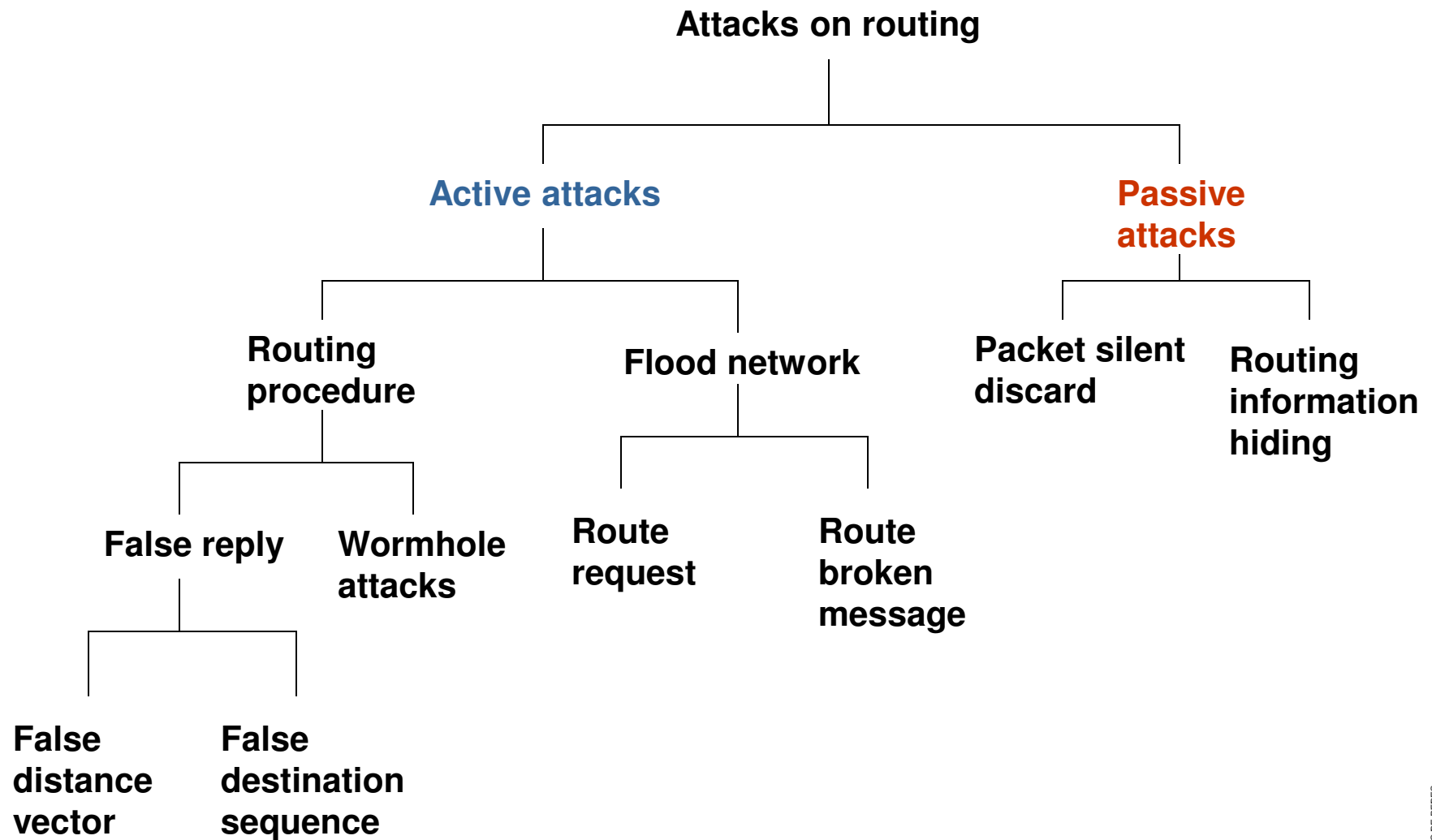

Blackhole attack detection using watchdogs

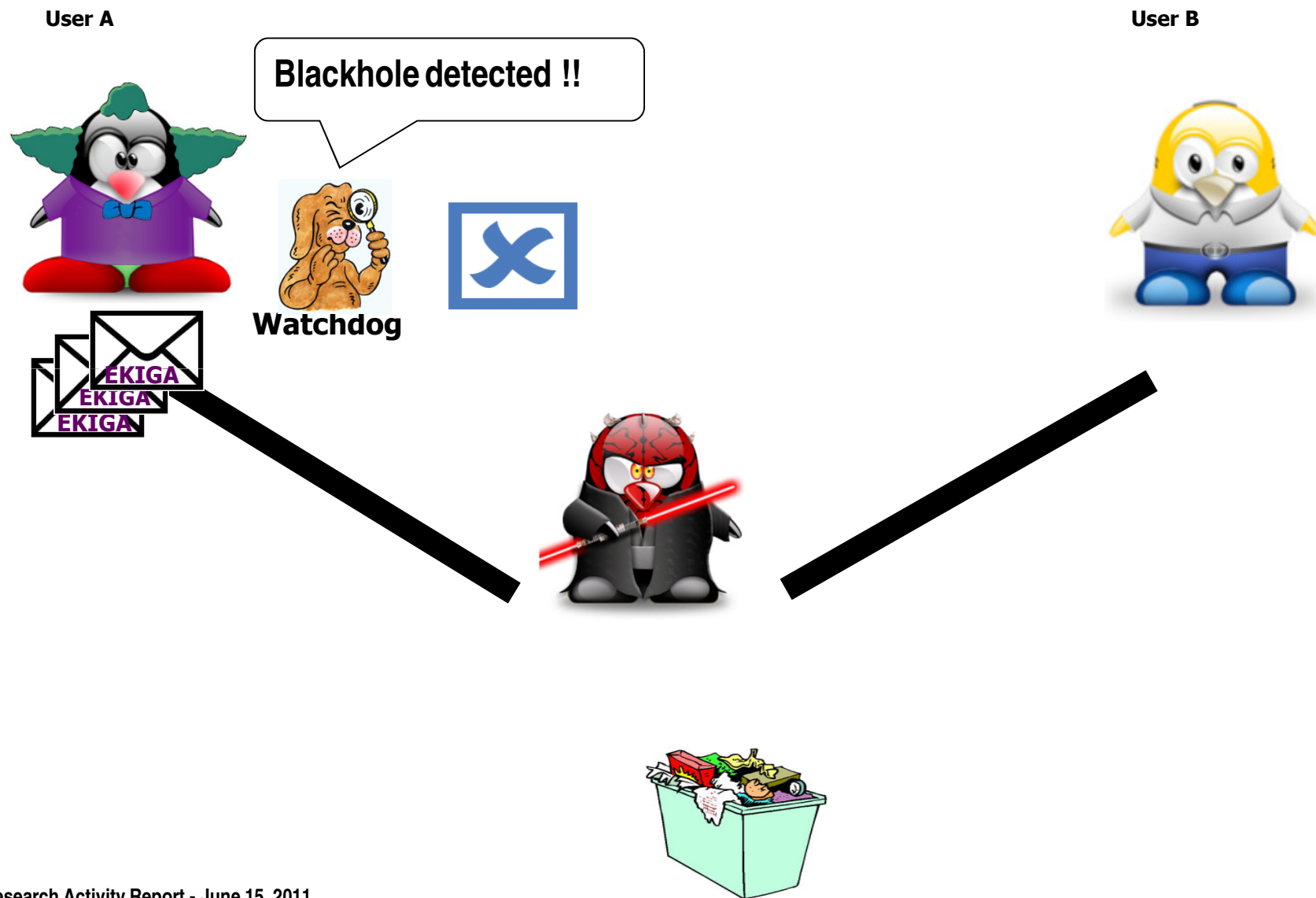

Active attacks detection: framework

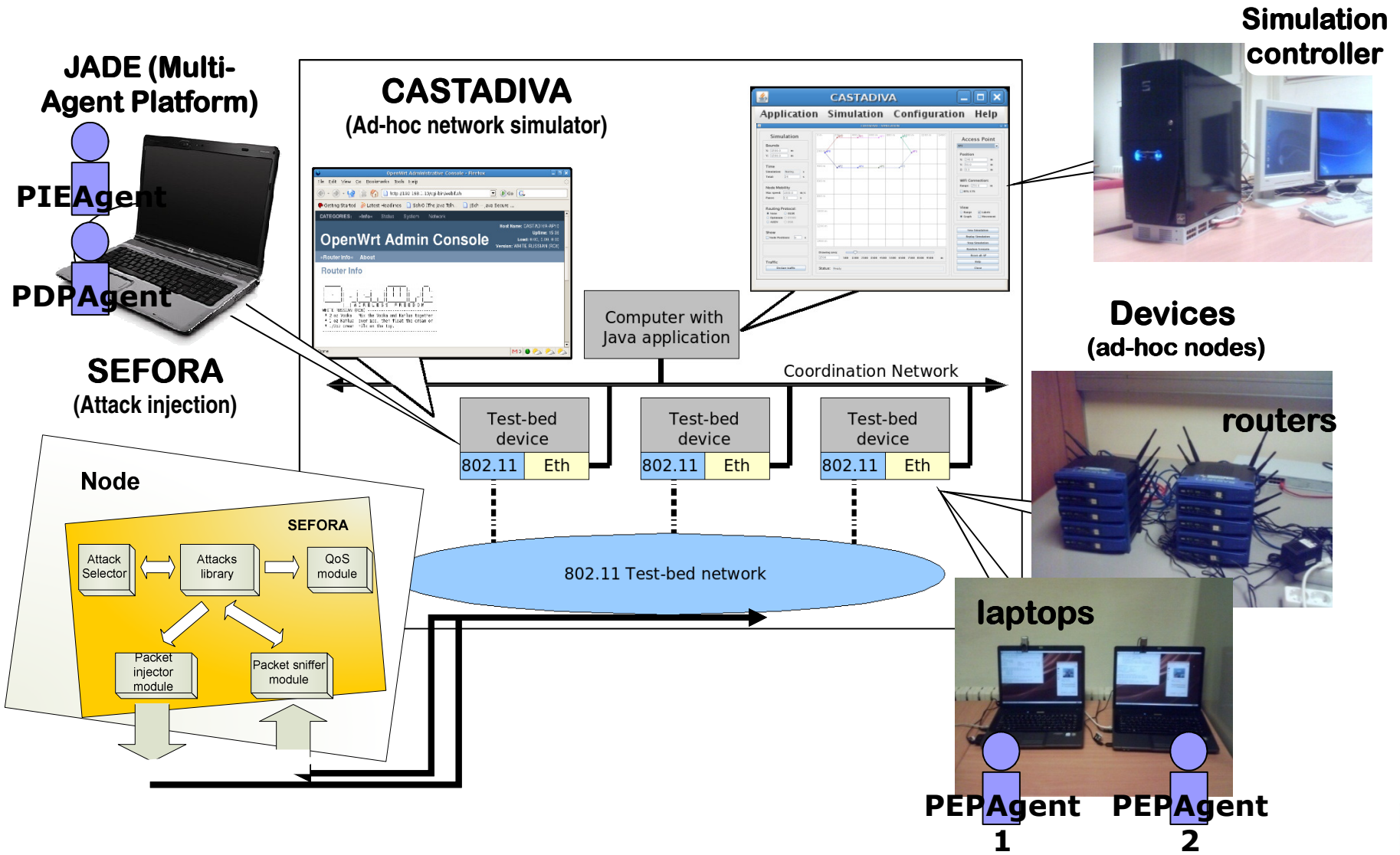

Anonymity (passive) attacks

- Correlate nodes' identities and their locations
- Visualize routes
- Visualize mobile nodes' motion patterns

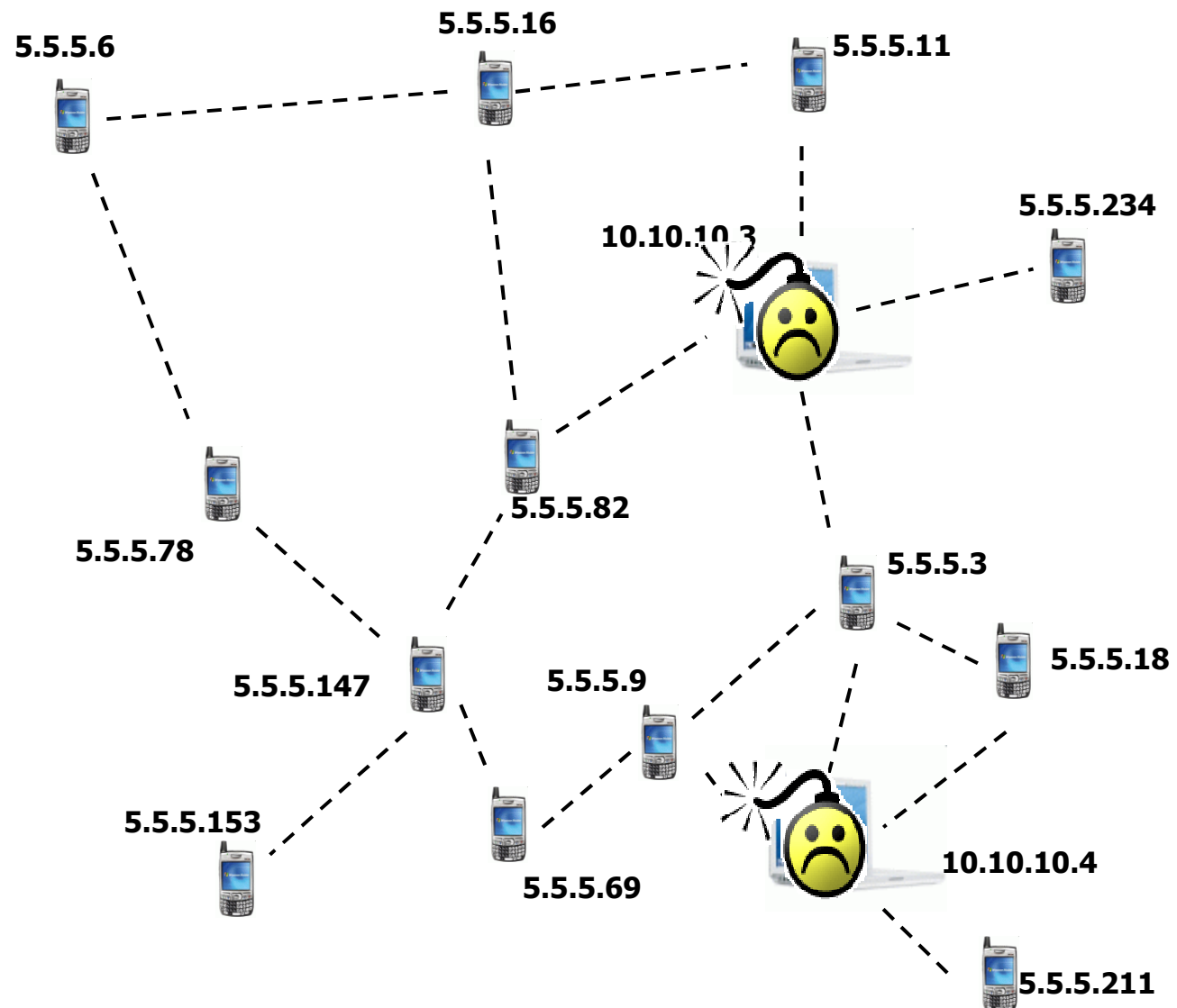

Ubiquitous Computing

- ❑ Ubiquimuseum
- ❑ Bluefriend
- ❑ Bluemall
- ❑ UbiquBioparc

UbiqMuseum: System Architecture

MCDS: Museum Central Data Server
 MIP: Museum Information Points
 MIC: Museum information clients

The final configuration Depends on the physical structure of the facilities

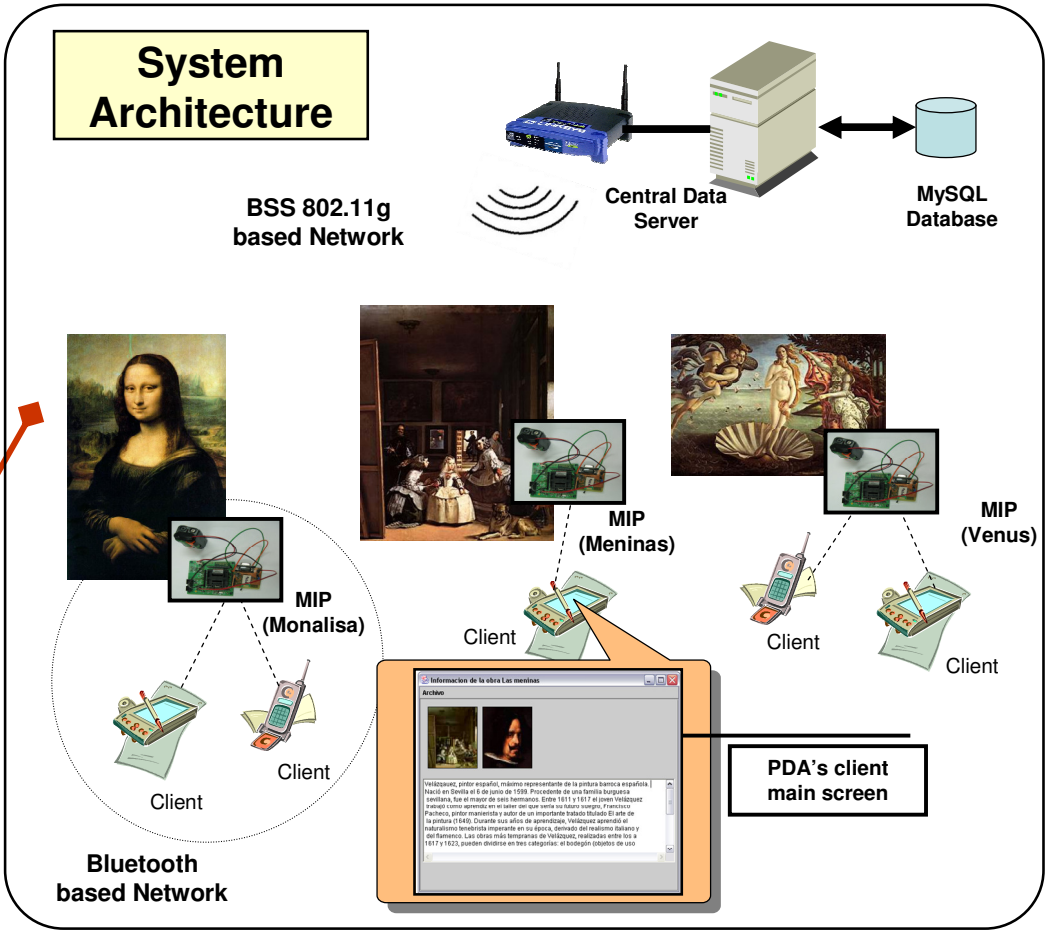

MIP Bluetooth Prototype: Schematic overview

- ❑ Based on commercial off-the-shelf components
 - ❑ Bluetooth transceiver
 - *Implements the Radio Base-Band and the Link Manager*
 - ❑ MIPs microprocessor
 - *HCI and L2CAP firmware*

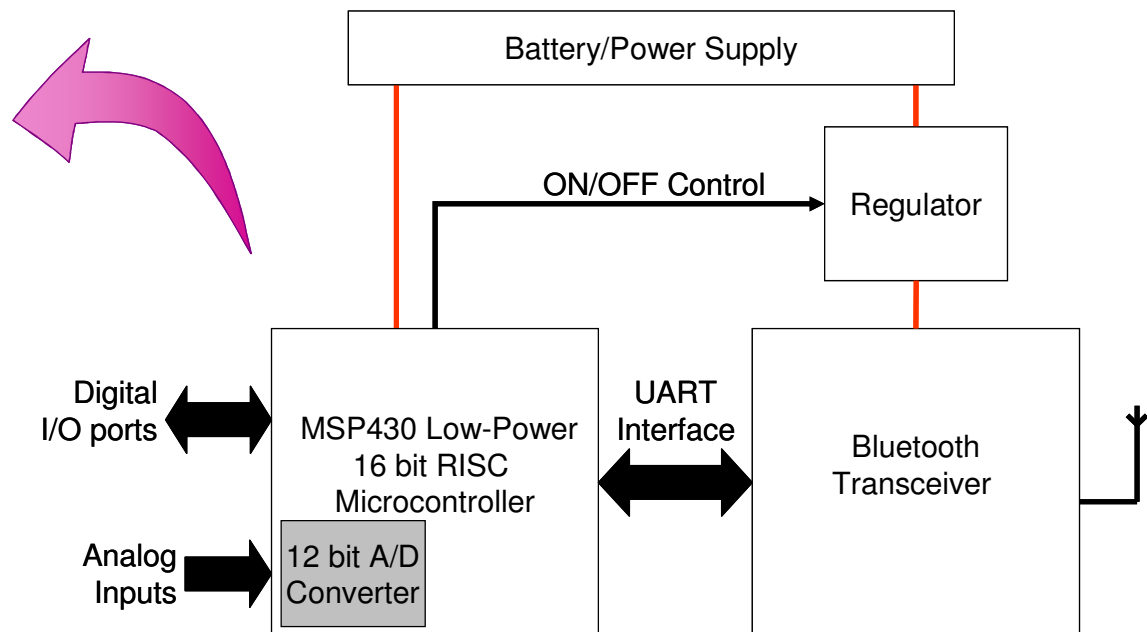
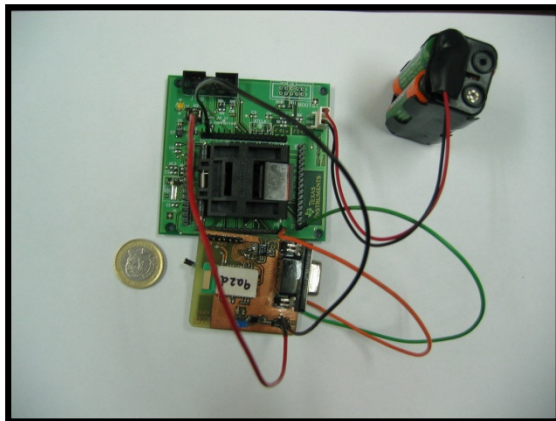

- ❑ Bluefriend, an application based on Bluetooth to create mobile social networks.
- ❑ Bluefriend periodically scans the environment in search for other members of the Bluefriend community;
 - ❑ when found, “virtual personal cards” (VPCs) are exchanged with information about: user preferences, likes/dislikes, etc. to assess the degree of matching among found users.
 - ❑ High degrees of matching result in the exchange of personal information and contact details so that connected users are aware of how to reach each other in a future.



BlueFriend: creating a profile

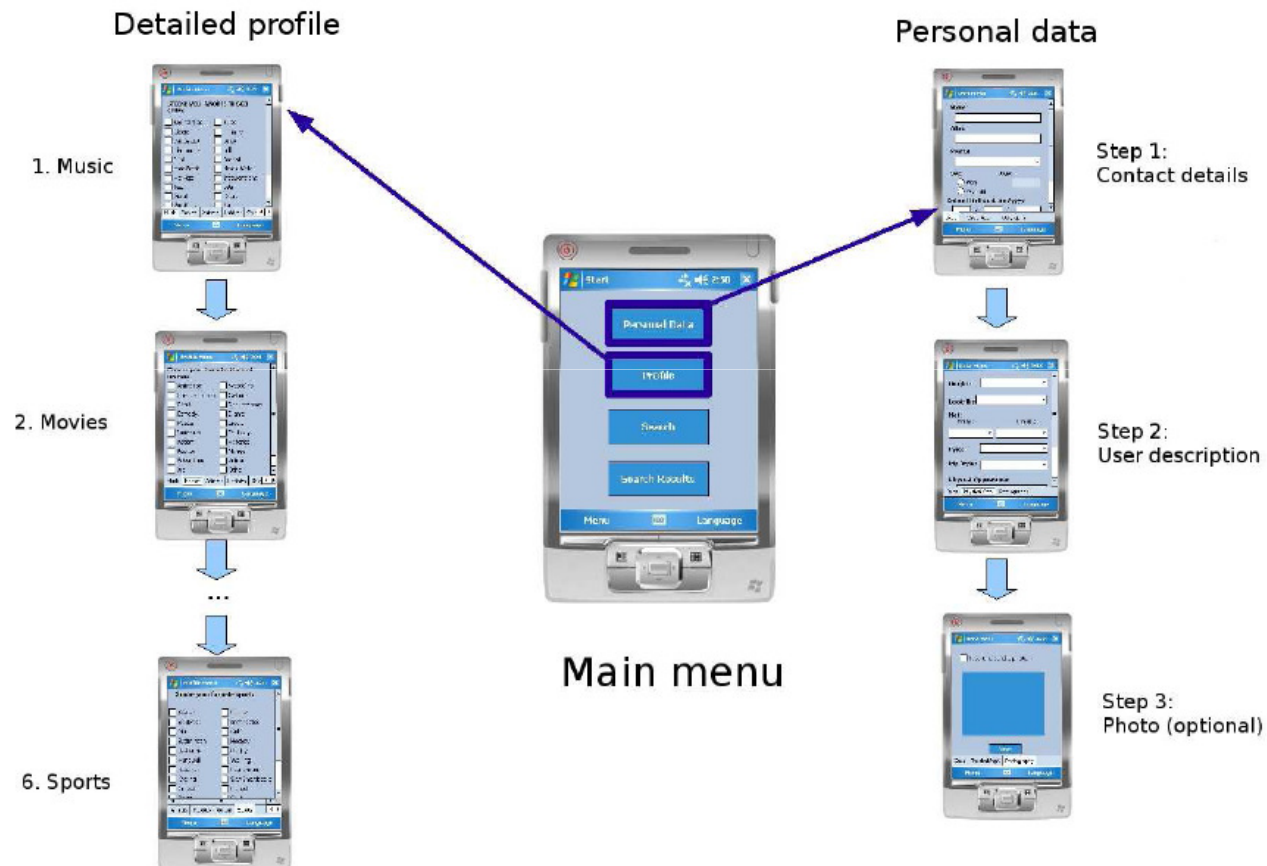



- ❑ Advertising system based on Bluetooth.
- ❑ Bluetooth terminals receive data with advertising content (mainly) sent from various access points.
- ❑ These contents are controlled in a centralized manner.



BlueMail: components general scheme

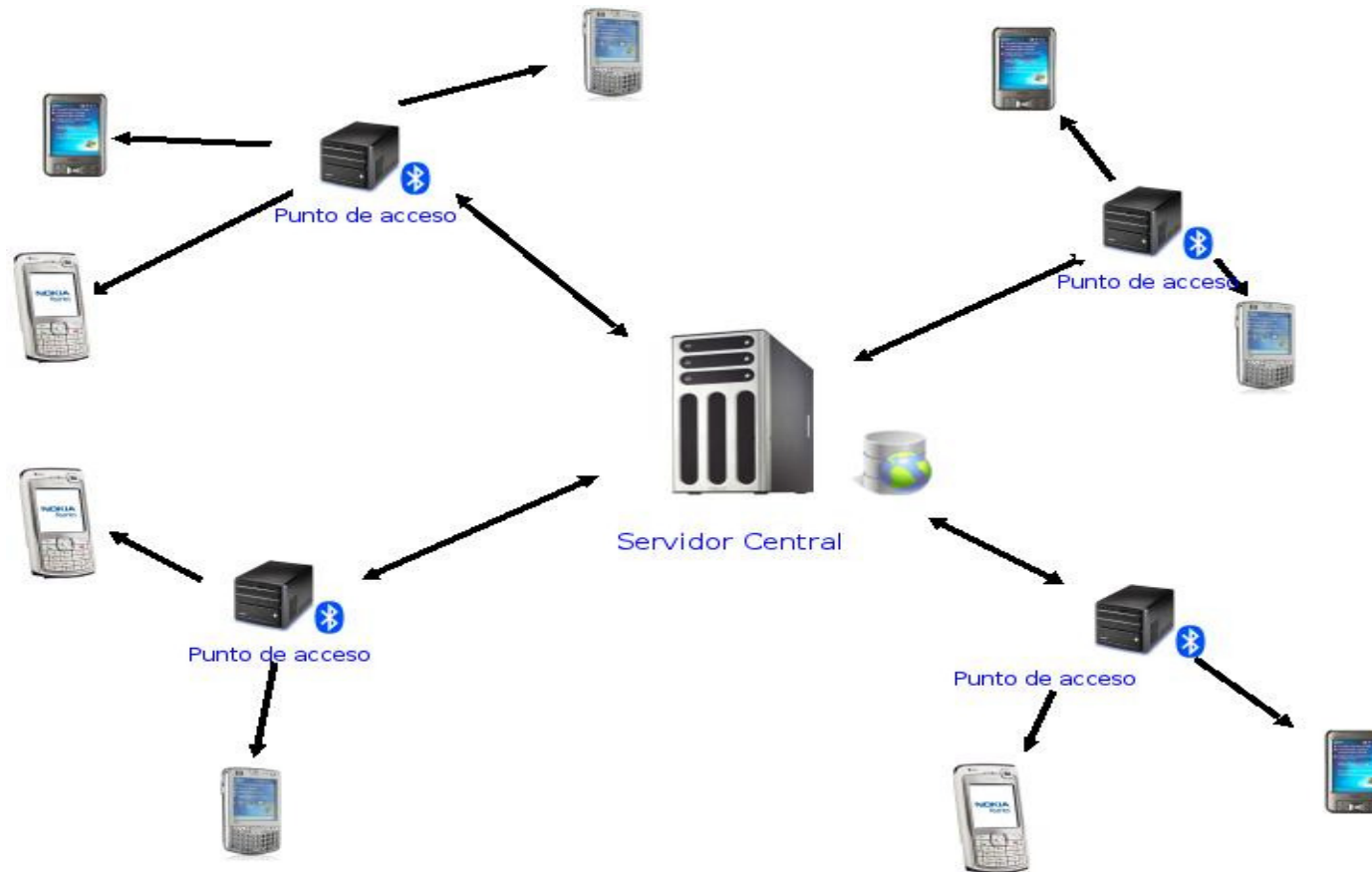



Central server

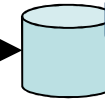
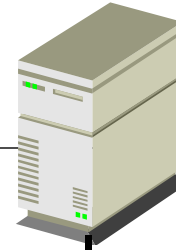

UbiqBIOPARC

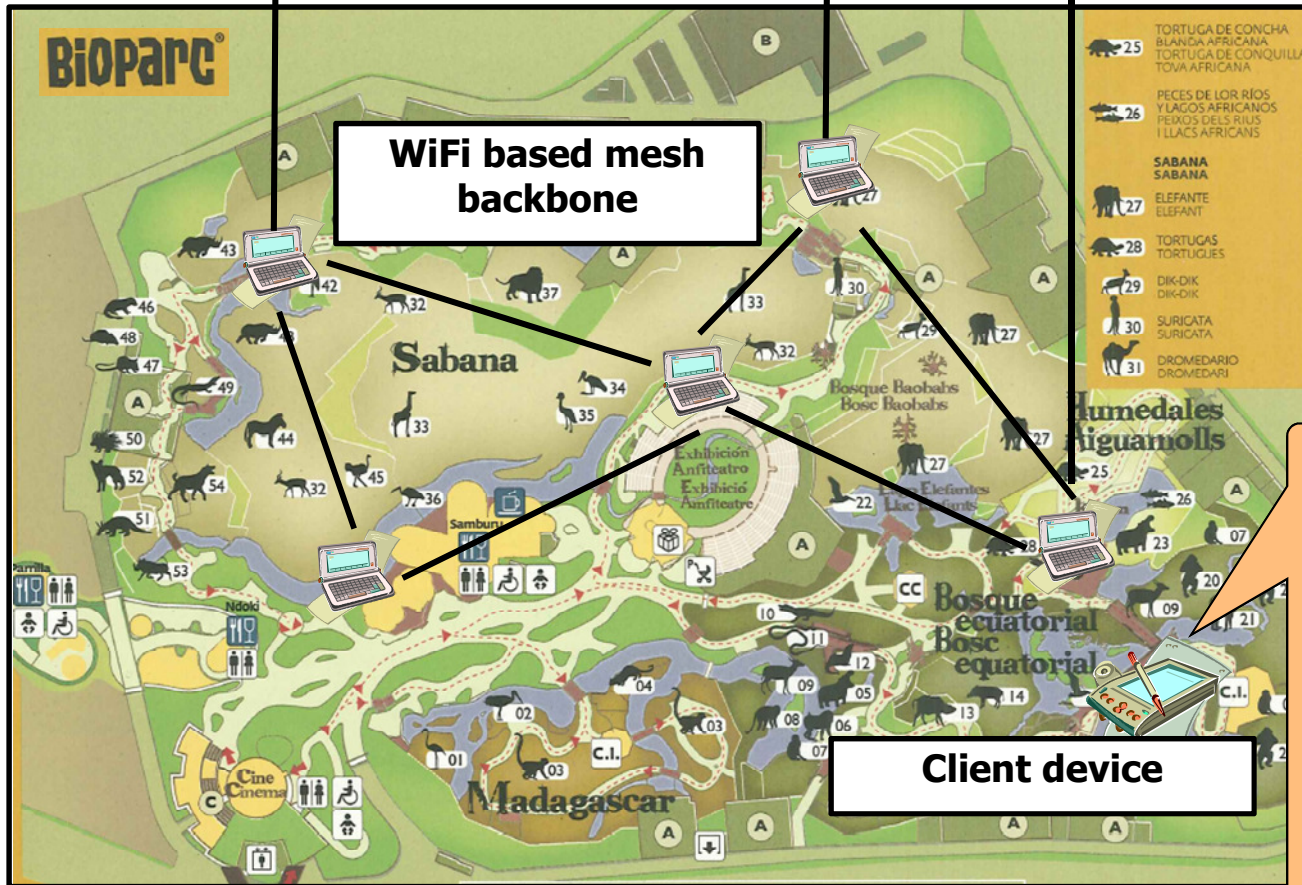

WiFi based mesh backbone

Client device

Views! 8:36 PM

GPSMuseum

RINOCERONTE BLANCO SUREÑO

★★★★★

FICHA TÉCNICA

Clase: Mammalia.
Orden: Perissodactyla.
Familia: Rhinocerotidae.
Especie: *Ceratotherium simum simum*.
Distribución geográfica: principalmente Sudáfrica, aunque también existen poblaciones menores en Botsuana, Zimbabue, Namibia y Gambia. Existe una pequeña población introducida en Kenia.
Hábitat: zonas de sabana herbácea con hierbas bajas, acceso a sombra y fuente de agua.
Dieta: pastizales, prefiriendo especies herbáceas de menor altura.
Periodo de gestación: 515 días.
Número de crías: 1 cría.
Esperanza de vida: 45 años.

BIOLOGIA Y COMPORTAMIENTO:

El rinoceronte blanco sureño presenta un morro cuadrado

UbiqBIOPARC: User Interface

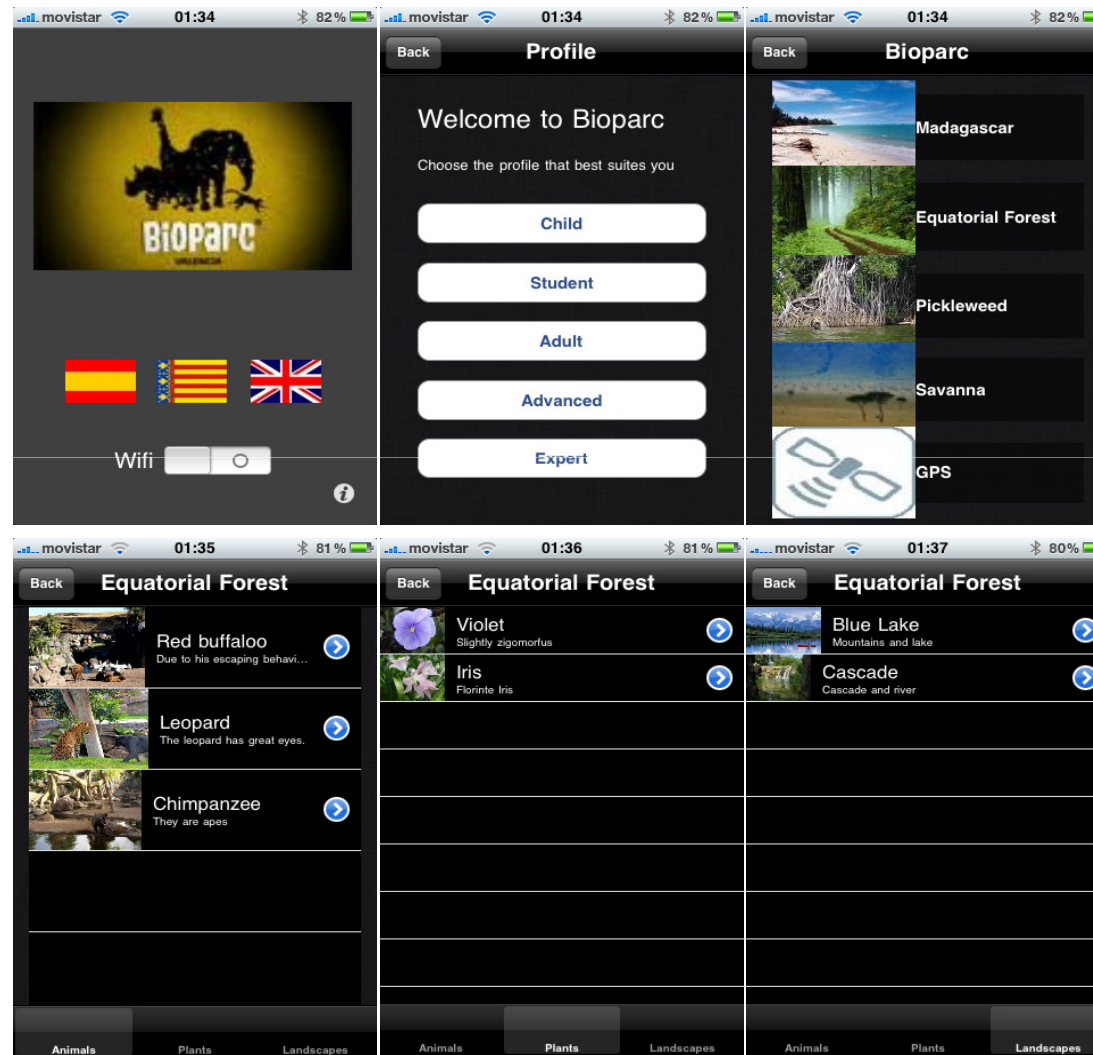

UbiqBIOPARC: using GPS and gyroscope

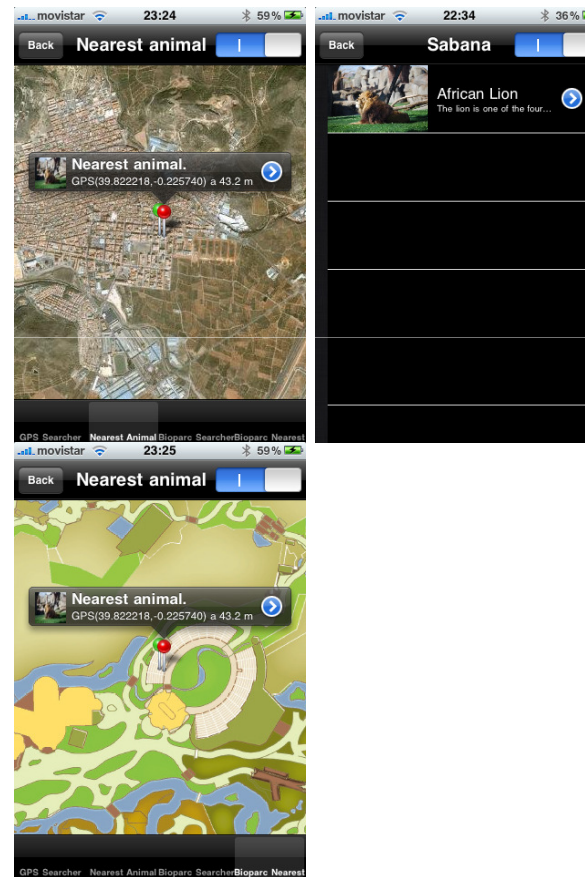
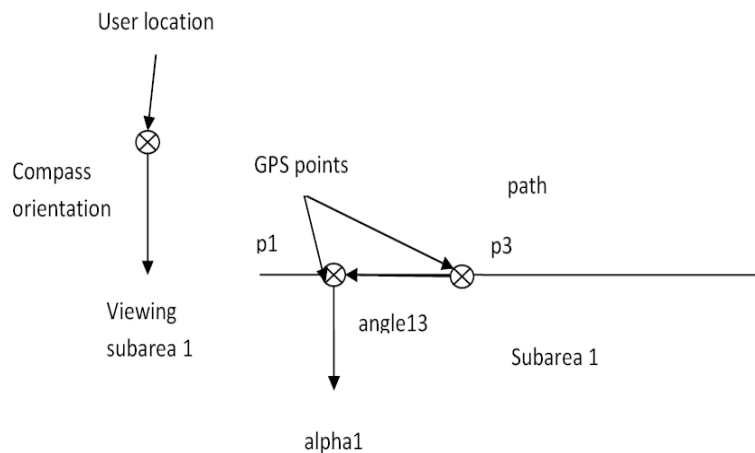
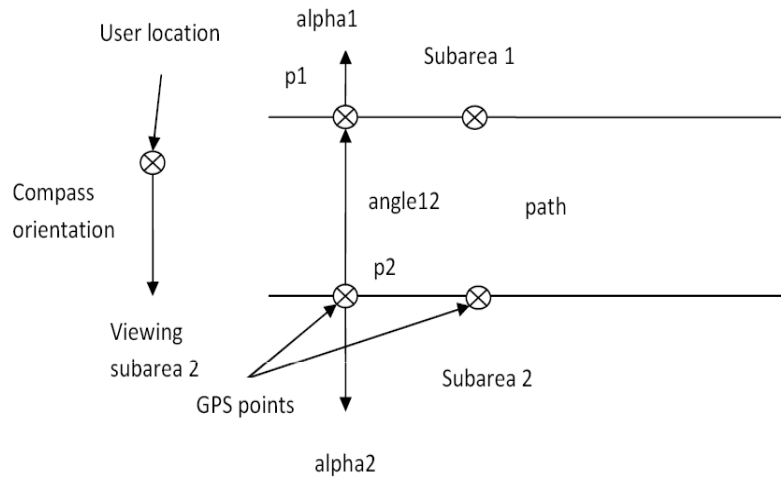

EasyMANET: VisualDNS

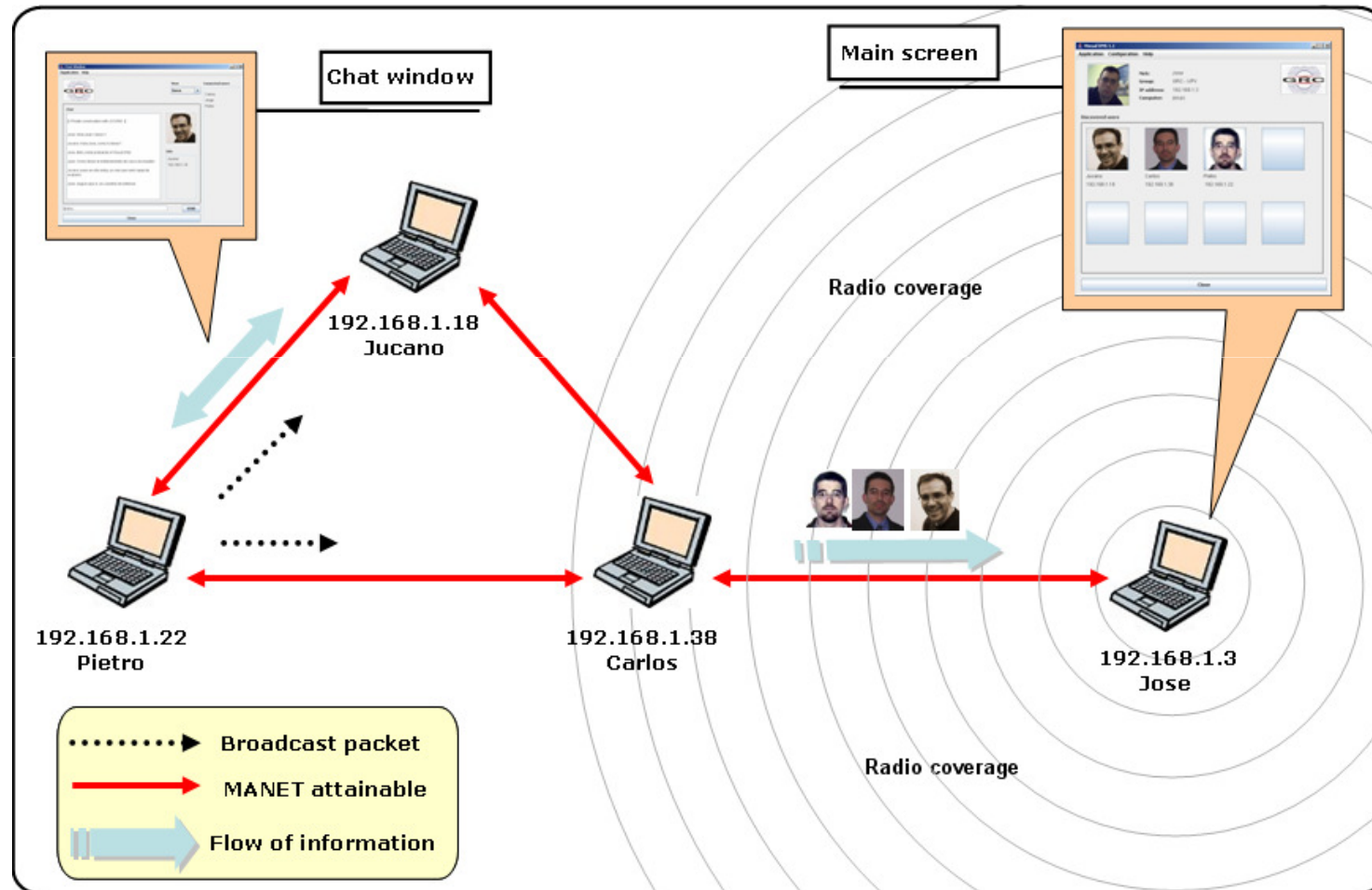

Multimedia Content Delivery

- DACME
- DACME-SV

DACME architecture

- ❑ The proposal involves and integrates three elements
 - ❑ Transport layer and middleware
 - *Distributed Admission Control for Manets Environments (DACME)*
 - ❑ Routing layer
 - *Multiple paths as an extension of a standard protocol (MDSR)*
 - ❑ MAC layer
 - *IEEE 802.11e*

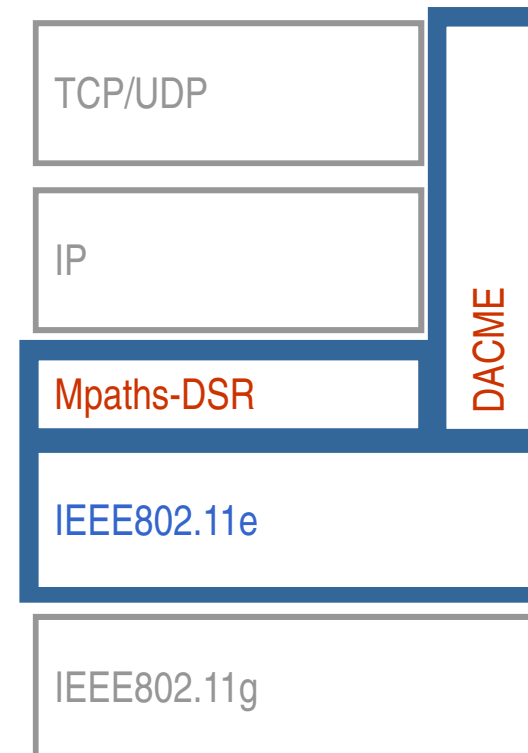

DACME architecture

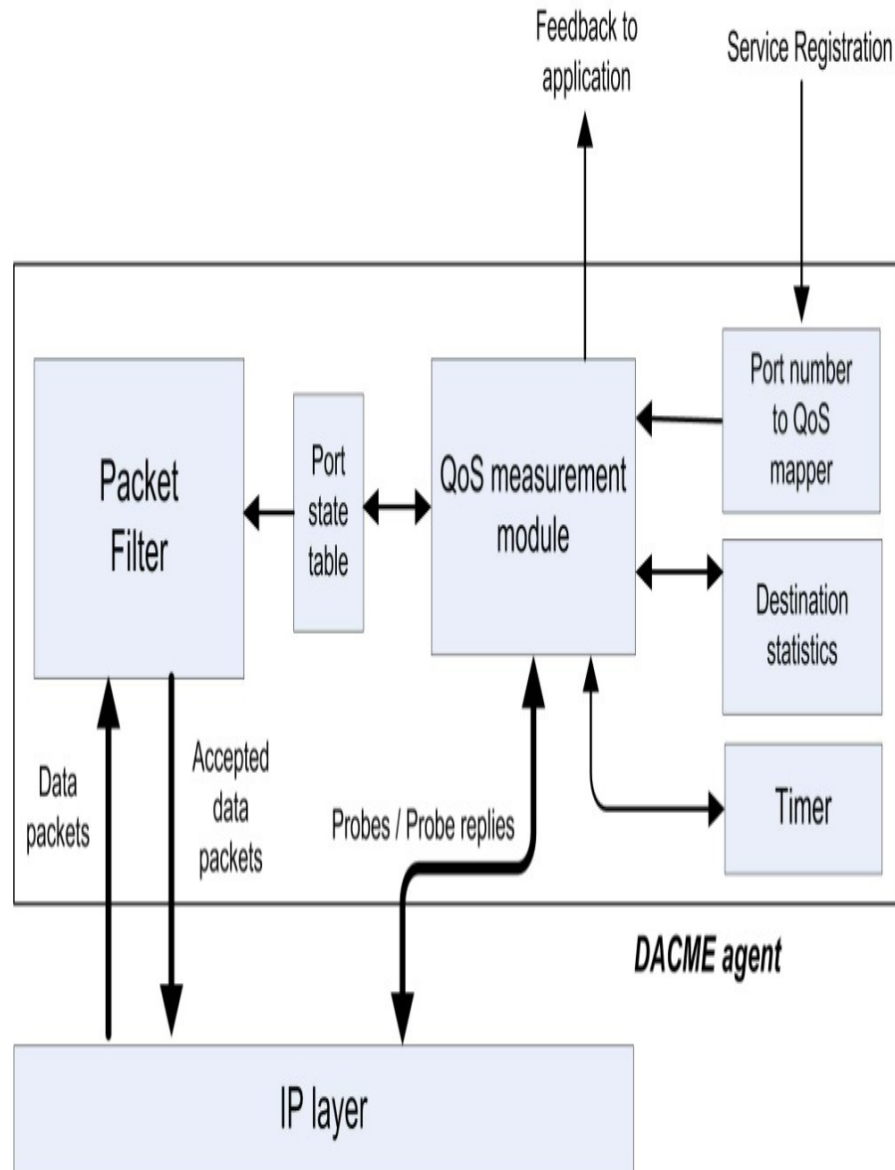

- ❑ The application registers with DACME, indicating the source port, as well as the destination's port and IP address
- ❑ DACME periodically sends probes to assess available bandwidth on the path
- ❑ The port state is set to up or down according to current network conditions
- ❑ The packet filter module is responsible for enforcing accept/reject decisions, and also for changing the packet's TOS field if accepted

DACME-SV: Goals

- ❑ Extend DACME to support scalable video.
 - ❑ Pass from a single-level video output to a multi-level video output. (see figures below)
 - ❑ Decrease Idle times.
- ❑ With DACME-SV, path information is used by the source to decide how many video layers can be transmitted over the network without congesting it, thus guaranteeing that traffic will not exceed network capacity.

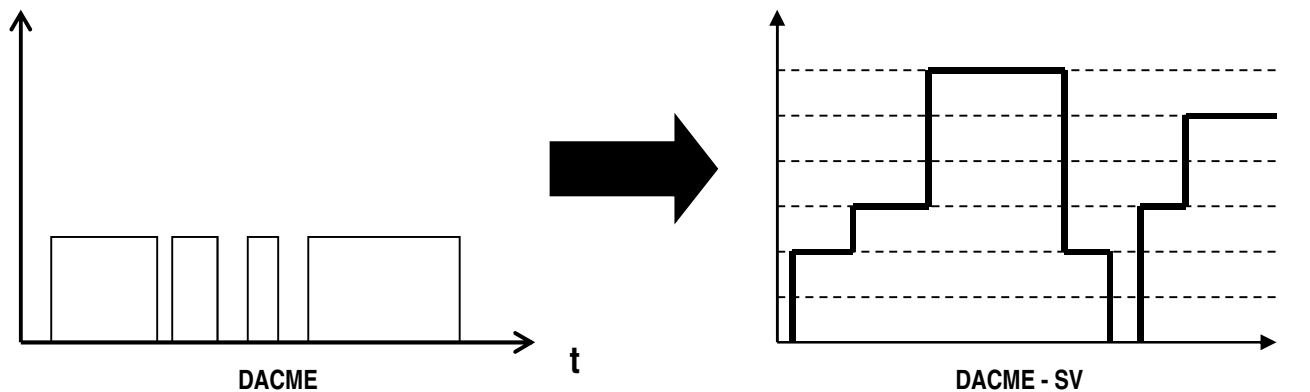

DACME testbed

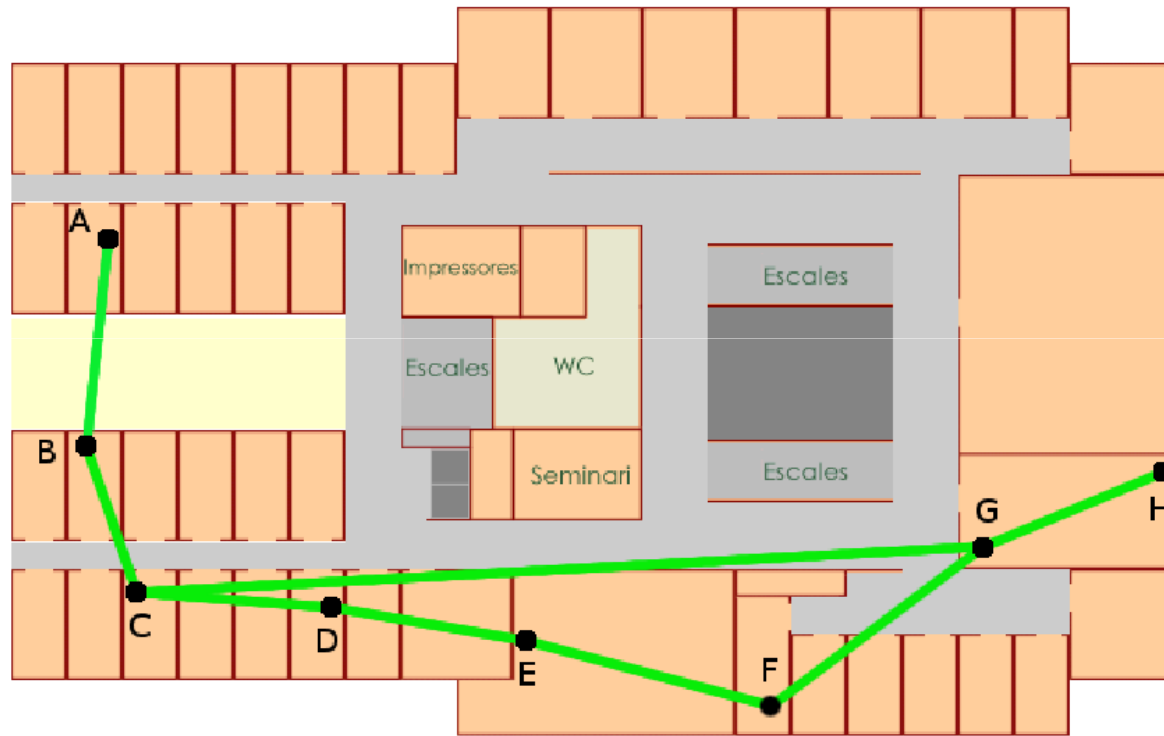

More information @ <http://www.grc.upv.es/>

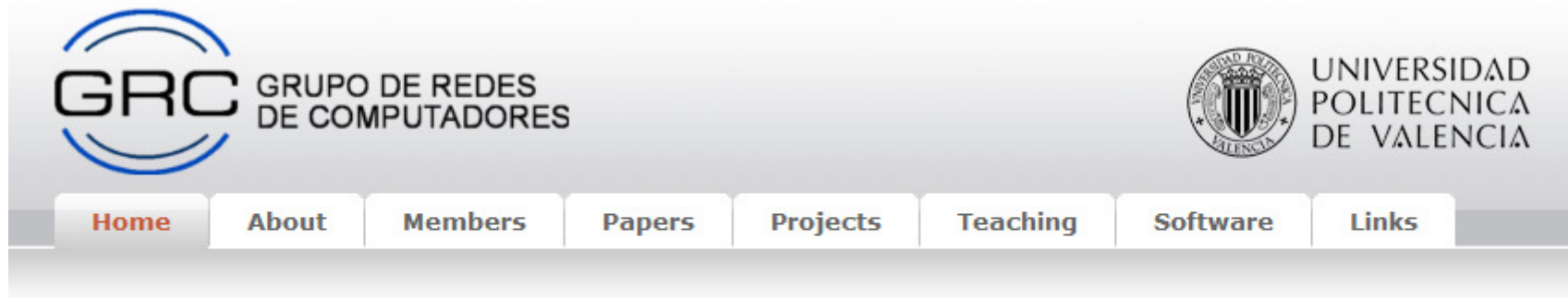

Blogs:

- ▶ [Noticias del GRC](#)
- ▶ [Call for Papers](#)
- ▶ [Photos in Picasa](#)

Conferences:

- ▶ [IEEE IVCS 2010](#)
- ▶ [IEEE IVCS 2011](#)
- ▶ [IEEE Vehi-Mobi 2010](#)
- ▶ [IFIP Networking 2011](#)